

THIS FILE IS MADE AVAILABLE THROUGH THE DECLASSIFICATION EFFORTS AND RESEARCH OF:

THE BLACK VAULT

THE BLACK VAULT IS THE LARGEST ONLINE FREEDOM OF INFORMATION ACT / GOVERNMENT RECORD CLEARING HOUSE IN THE WORLD. THE RESEARCH EFFORTS HERE ARE RESPONSIBLE FOR THE DECLASSIFICATION OF THOUSANDS OF DOCUMENTS THROUGHOUT THE U.S. GOVERNMENT, AND ALL CAN BE DOWNLOADED BY VISITING:

[HTTP://WWW.BLACKVAULT.COM](http://www.blackvault.com)

YOU ARE ENCOURAGED TO FORWARD THIS DOCUMENT TO YOUR FRIENDS, BUT PLEASE KEEP THIS IDENTIFYING IMAGE AT THE TOP OF THE .PDF SO OTHERS CAN DOWNLOAD MORE!

NASA TECHNICAL NOTE



NASA TN D-7992

NASA TN D-7992

(NASA-TN-D-7992) APOLLO EXPERIENCE REPORT:
GUIDANCE AND CONTROL SYSTEMS. MISSION
CONTROL PROGRAMMER FOR UNMANNED MISSIONS
AS-202, APOLLO 4, AND APOLLO 6 (NASA) 60 p
HC \$4.25

N75-27024

Unclass
28542

CSCL 22B H1/12

**APOLLO EXPERIENCE REPORT -
GUIDANCE AND CONTROL SYSTEMS:
MISSION CONTROL PROGRAMMER FOR
UNMANNED MISSIONS AS-202,
APOLLO 4, AND APOLLO 6**

*Gene F. Holloway
Lyndon B. Johnson Space Center
Houston, Texas 77058*



NATIONAL AERONAUTICS AND SPACE ADMINISTRATION • WASHINGTON, D. C. • JULY 1975

1. Report No. NASA TN D-7992	2. Government Accession No.	3. Recipient's Catalog No.
4. Title and Subtitle APOLLO EXPERIENCE REPORT GUIDANCE AND CONTROL SYSTEMS: MISSION CONTROL PROGRAMMER FOR UNMANNED MISSIONS AS-202, APOLLO 4, AND APOLLO 6		5. Report Date July 1975
7. Author(s) Gene F. Holloway		6. Performing Organization Code JSC-04214
9. Performing Organization Name and Address Lyndon B. Johnson Spacecraft Center Houston, Texas 77058		8. Performing Organization Report No. S-432
12. Sponsoring Agency Name and Address National Aeronautics and Space Administration Washington, D. C. 20546		10. Work Unit No. 953-36-00-00-72
15. Supplementary Notes		11. Contract or Grant No.
16. Abstract An unmanned test flight program was required to evaluate the command module heat shield and the structural integrity of the command and service module/Saturn launch vehicle. The mission control programmer was developed to provide the unmanned interface between the guidance and navigation computer and the other spacecraft systems for mission event sequencing and real-time ground control during missions AS-202, Apollo 4, and Apollo 6. The development of this unmanned programmer is traced from the initial concept through the flight test phase. Detailed discussions of hardware development problems are given with the resulting solutions. The mission control programmer functioned correctly without any flight anomalies for all missions. The Apollo 4 mission control programmer was reused for the Apollo 6 flight, thus being one of the first subsystems to be reflown on an Apollo space flight.		13. Type of Report and Period Covered Technical Note
17. Key Words (Suggested by Author(s)) • Unmanned Mission • Command Guidance • Spacecraft Guidance • Automatic Flight Control • Control Systems		14. Sponsoring Agency Code
18. Distribution Statement STAR Subject Category: 12 (Astronautics, General)		15. Supplementary Notes
19. Security Classif. (of this report) Unclassified	20. Security Classif. (of this page) Unclassified	21. No. of Pages 60
		22. Price* \$4.25

* For sale by the National Technical Information Service, Springfield, Virginia 22151

CONTENTS

Section	Page
SUMMARY	1
INTRODUCTION	1
MISSION CONTROL PROGRAMER DESCRIPTION	2
Input Keying Commands for Mission Sequencing	3
Sequencing To Accomplish Mission Requirements	8
Real-Time Commands for Ground Control	15
Backup 0.05g Acceleration Sensor	19
Sequencing Postlanding Recovery Aids	21
DESIGN USING EXISTING TECHNOLOGY	23
Spacecraft Command Controller	23
Ground Command Controller	28
Attitude and Deceleration Sensor	29
TEST EQUIPMENT DESIGN	30
DEVELOPMENT SCHEDULES AND TEST PROGRAM	32
Breadboard and Prototype Development	33
Electromagnetic-Interference Considerations	33
Test Equipment Certification	34
Production Delivery	35
Qualification Tests	35
Interface Verification Tests	39
Spacecraft Tests	41
HARDWARE PROBLEMS AND RESOLUTIONS	43
Reliability and Quality Objectives	43

--	--	--	--	--	--	--	--

Section	Page
Relay Failures	43
Solder Contamination in MCP Relays	44
Polarized Tantalum Capacitor Failures	45
Time-Delay Failures	45
Cracking of Glass Seals Caused by Clipping of Relay Pins	49
FLIGHT PERFORMANCE	50
Mission AS-202	50
Apollo 4 Mission	51
Apollo 6 Mission	51
CONCLUDING REMARKS AND RECOMMENDATIONS	52
Unmanned Flight Planning	52
Development Schedule	52
Test and Test Equipment	52
Hardware Problems	53

TABLES

Table	Page
I APOLLO 4 MISSION DISCRETE EVENTS SUMMARY	10
II NOMINAL MISSION SEQUENCE OF EVENTS FOR SECOND SPS FIRING	13
III REAL-TIME COMMANDS	16
IV NOMINAL MISSION SEQUENCE OF EVENTS FROM ENTRY TO LANDING	20
V NOMINAL MISSION RECOVERY SEQUENCE OF EVENTS	21
VI RELAY FAILURE HISTORY	44

FIGURES

Figure	Page
1 Mission control programer	3
2 Spacecraft command controller	4
3 Attitude and deceleration sensor	5
4 Block diagram of the MCP	6
5 Diagram of the G&N system connector interface with the SCC	7
6 Diagram of the S-IVB IU interface with the SCC	8
7 Diagram of launch control and GSE interface with the SCC	9
8 Circuit logic and switching relays	
(a) Simplex (not redundant)	23
(b) Dual series (redundant)	23
(c) Dual parallel (redundant)	23
(d) Dual series, triply parallel (redundant)	23
9 Cable assembly wire harness	25
10 Printed wiring board with components	26

Figure		Page
11	Bracket showing relays and time-delay mountings	27
12	Automatic checkout equipment interface requirements for the MCP redundancy test	28
13	Qualification testing sequence	36
14	Fractured solder terminals	
	(a) Example 1	38
	(b) Example 2	38
	(c) Example 3	38
15	Repair method, soldering backside of terminal strip	
	(a) Orientation of rework area	39
	(b) Closeup of rework area	39
16	Typical diode mounting bracket	40
17	Time-delay circuit schematic	46
18	Relay schematics to describe glass-seal problem	
	(a) Bottom view of relay-case header	50
	(b) Top view of relay pins with contacts in open configuration	50
	(c) Cross section of pin entering relay header and the glass seal	50

APOLLO EXPERIENCE REPORT
GUIDANCE AND CONTROL SYSTEMS: MISSION CONTROL PROGRAMMER
FOR UNMANNED MISSIONS AS-202, APOLLO 4, AND APOLLO 6

By Gene F. Holloway
Lyndon B. Johnson Space Center

SUMMARY

The unmanned Apollo missions AS-202, Apollo 4, and Apollo 6 were successful flights. The flight objectives, which were a prerequisite for the manned Apollo missions, were accomplished for each mission. The mission control programmer unit was successfully used for all three missions without causing a flight anomaly or the loss of any functional event for which the programmer was responsible. The mission control programmer met all the flight and ground test objectives without the loss or erroneous indication of any necessary output. The mission control programmer did, however, experience individual component failures during the program. These few failures were compensated for in the redundant circuit design of the mission control programmer and did not result in the loss of or deficiency in any necessary mission output. Because the mission control programmer was designed for unmanned missions and a crew was not present to compensate for possible flight anomalies by switching to alternate backup systems or by using alternate mission modes, the mission control programmer with its sometimes triply redundant paths was required to have higher inherent reliability than other Apollo systems. The Apollo 4 mission control programmer was reflown during the Apollo 6 mission. This unit was the first Apollo system to be reflown on a space-flight mission.

INTRODUCTION

The structure and heat-shield design of the Apollo command and service module (CSM) had to be verified under Saturn V launch and lunar-reentry environments before it could be considered man-rated. The mission control programmer (MCP) was developed by the NASA and the CSM prime contractor to provide the automatic event switching interface between the input command and control systems (e. g., the guidance and navigation (G&N) computer) and the output response systems for the Apollo unmanned test flights. The MCP also provided the real-time ground-control interface for backup attitude control and sequencing. The objective of this report is to document the MCP development program from the initial concepts and mission requirements phase; through the design and manufacturing buildup testing; during the spacecraft installation and

tests; and, finally, through the launch, recovery, and postflight analysis. This Apollo experience resulted in useful information that should be adapted to the design of future unmanned space-flight equipment.

The unmanned flight requirements for the MCP were identified by the interfacing subsystem design engineers and ground flight controllers. This report gives a mission time line for the Apollo 4 mission and demonstrates how this mission was accomplished using a few key commands from the G&N computer and using the internal logic and hardwired time delays of the MCP to drive or switch the interfacing spacecraft systems. The backup ground-control capability is listed together with a description of each real-time ground command. An example is given to show how the ground commands could be used to provide a backup thrust maneuver.

The requirement to test each redundant path or system in the Apollo launch vehicle just before launch was an essential factor in the mission successes of the Apollo Program. This report discusses the problems that had to be resolved to perform these spacecraft redundancy tests on the MCP.

During the MCP development, changes to the spacecraft were approved that required design changes to the MCP. Some of the spacecraft changes are listed in this report together with their effect on the MCP design.

As an aid to the reader, where necessary the original units of measure have been converted to the equivalent value in the Système International d'Unités (SI). The SI units are written first, and the original units are written parenthetically thereafter.

MISSION CONTROL PROGRAMER DESCRIPTION

The MCP (fig. 1) consisted of three units: the spacecraft command controller (SCC; fig. 2), the ground command controller (GCC; similar to the SCC), and the attitude and deceleration sensor (ADS; fig. 3). These units were located in the spacecraft on a platform assembly mounted in place of the crew couches on the crew couch shock mounts. The MCP weight was adjusted to approximately 163 kilograms (360 pounds) so that it could provide the weight necessary to verify the response of the crew couch struts to landing impacts. As shown in figure 4, the keying commands were supplied to the MCP by the G&N system, the Saturn IVB (S-IVB) instrumentation unit (IU), the updata link, and the launch control complex. The other interfacing systems actuated by the MCP output switching functions are also shown in figure 4.

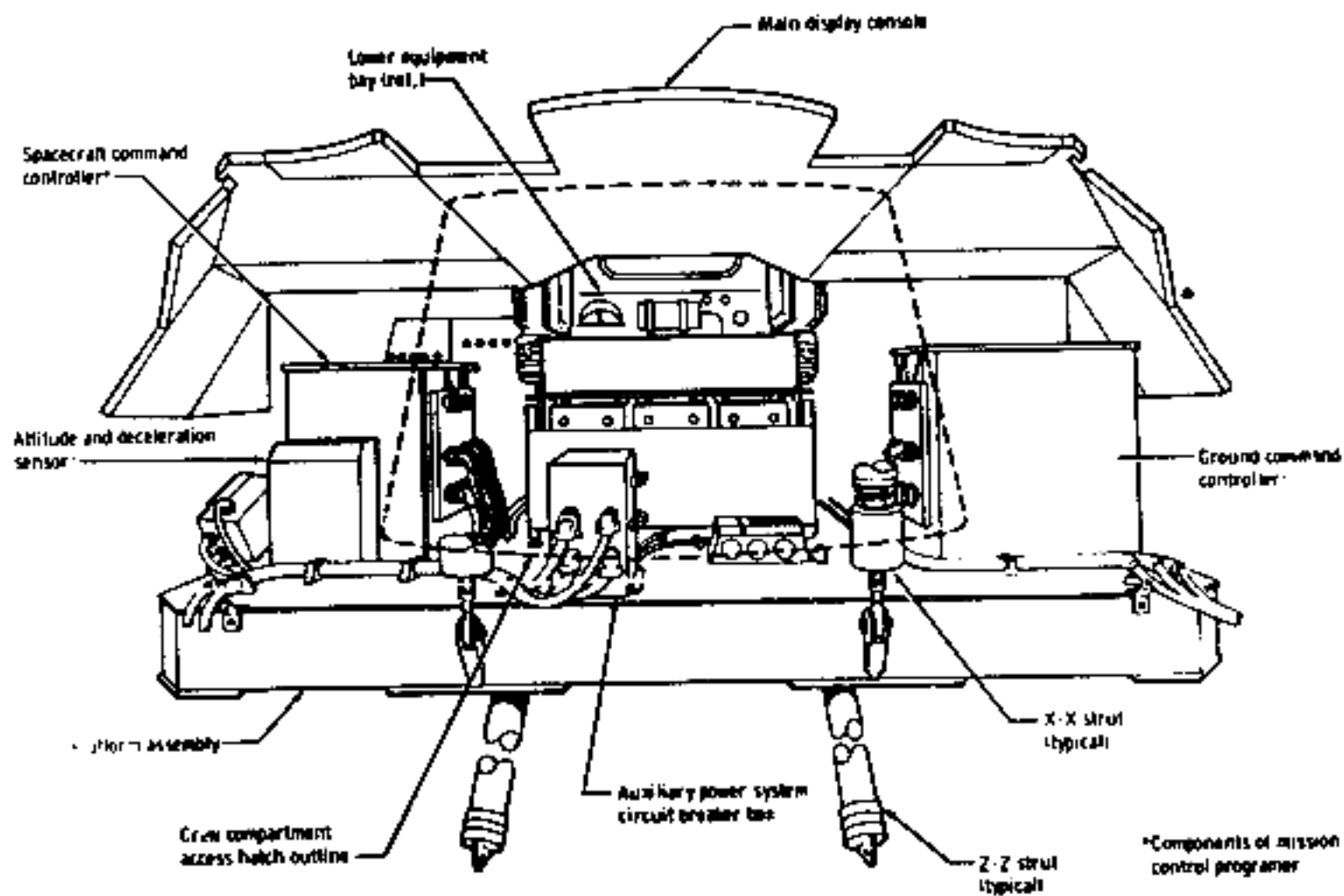

Figure 1. - Mission control programmer.

Input Keying Commands for Mission Sequencing

The primary source of mission sequencing key commands to the MCP was the G&N system computer. The original keying commands furnished by the G&N computer were as follows.

1. G&N abort
2. Positive- or negative-Z antenna switching
3. Flight director attitude indicator alignment
4. Gimbal motors
5. G&N fail
6. 0.05g
7. Positive-X translation

8. Command module (CM) and service module (SM) separation
9. G&N entry mode
10. G&N change in velocity ΔV mode
11. G&N attitude control mode

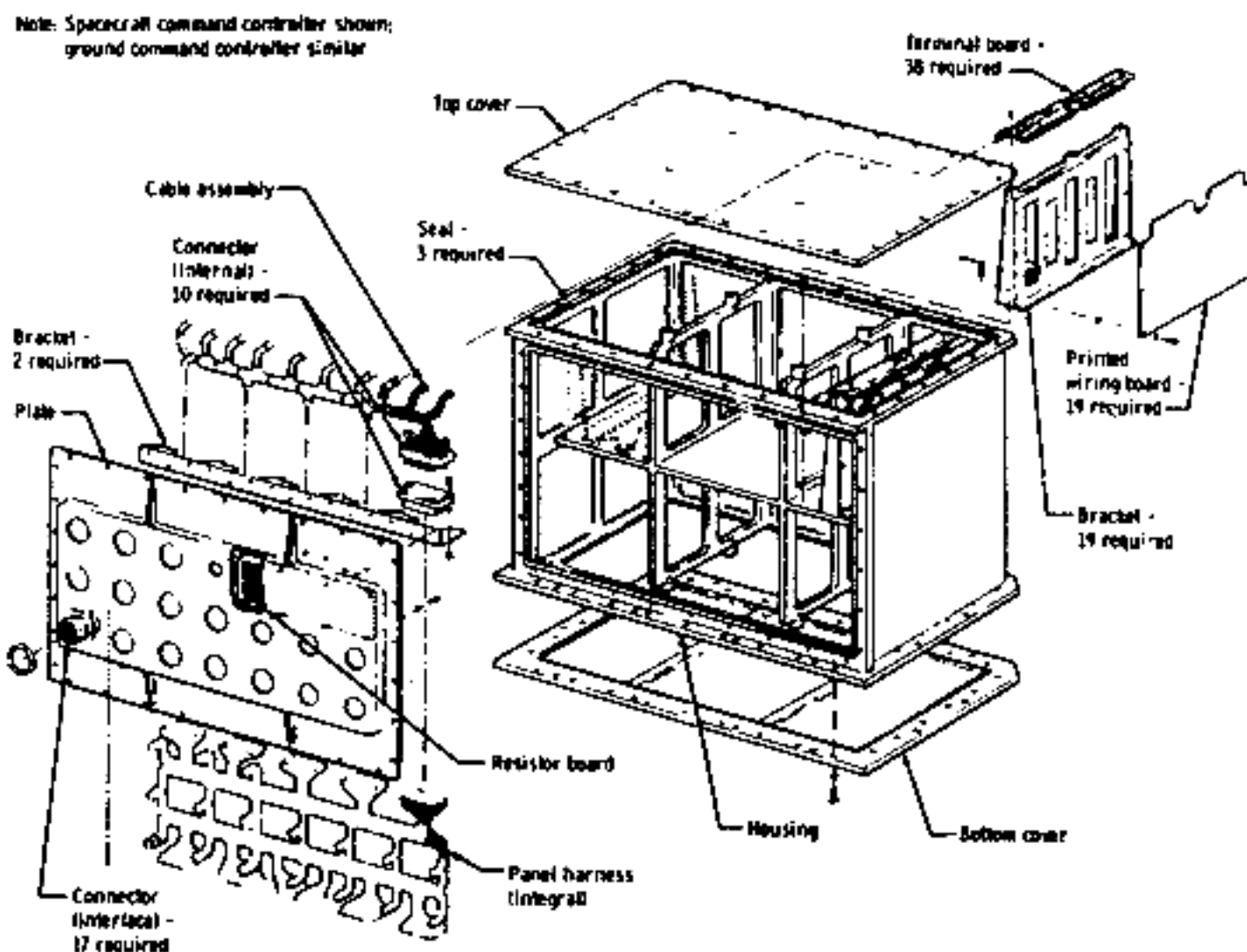

Figure 2. - Spacecraft command controller.

The first two interface signals, G&N abort and positive- or negative-Z antenna switching, were removed from the G&N wiring on spacecraft 017 and 020 because the failures that could produce either signal were considered to be single-point failures. The decision was made that, because the abort signal or relay closure could be erroneous, the G&N system computer should not automatically abort a mission. Because real-time ground commands were available to switch the antennas and because the G&N system computer controlled the spacecraft attitude during the mission midcourse flightpath,

the software task of programing the G&N system computer to switch antennas automatically was considered too costly for the results achieved. The diagram of the connector interface between the MCP and the G&N system computer (fig. 5) shows that the MCP provided the 28-V dc power supply for the G&N system relays, and the G&N system computer provided the logic and relay closures to complete the circuit paths.

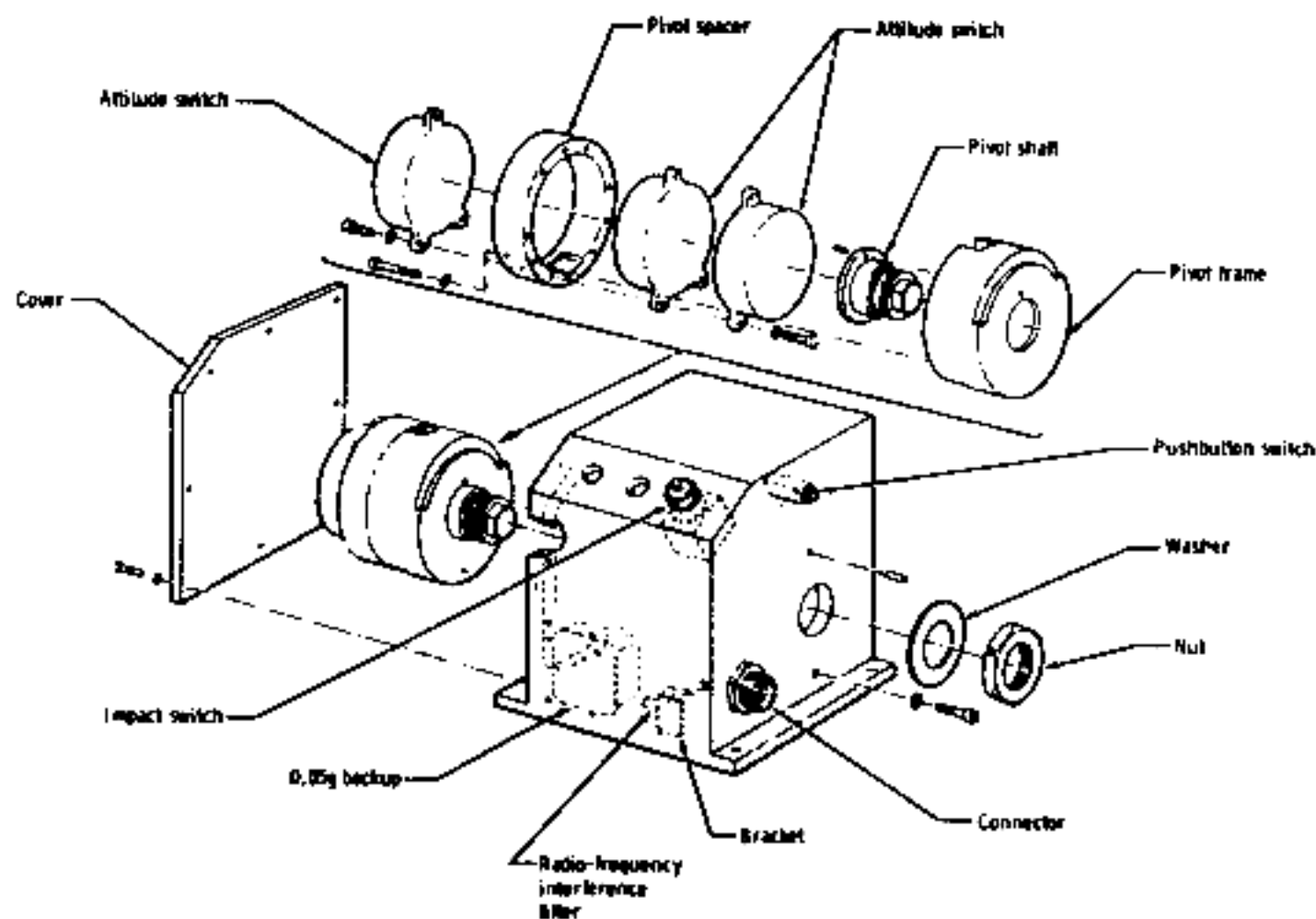

Figure 3. - Attitude and deceleration sensor.

The S-IVB IU provided four keying commands for the MCP. The following list represents the S-IVB interface keying commands for mission sequencing. Each command was dually redundant.

1. S-IVB restart A
2. S-IVB restart B
3. Launch escape tower jettison command A
4. Launch escape tower jettison command B
5. Lift-off signal A

6. Lift-off signal B
7. Launch vehicle and spacecraft separation start A
8. Launch vehicle and spacecraft separation start B

Whenever the spacecraft direct-current bus was powered, the MCP provided redundant direct-current power to the S-IVB IU for the generation of the discrete sequencing signals (fig. 6). These keying signals from the IU were used by the MCP logic and internal time-delay circuits to provide the other required mission sequences.

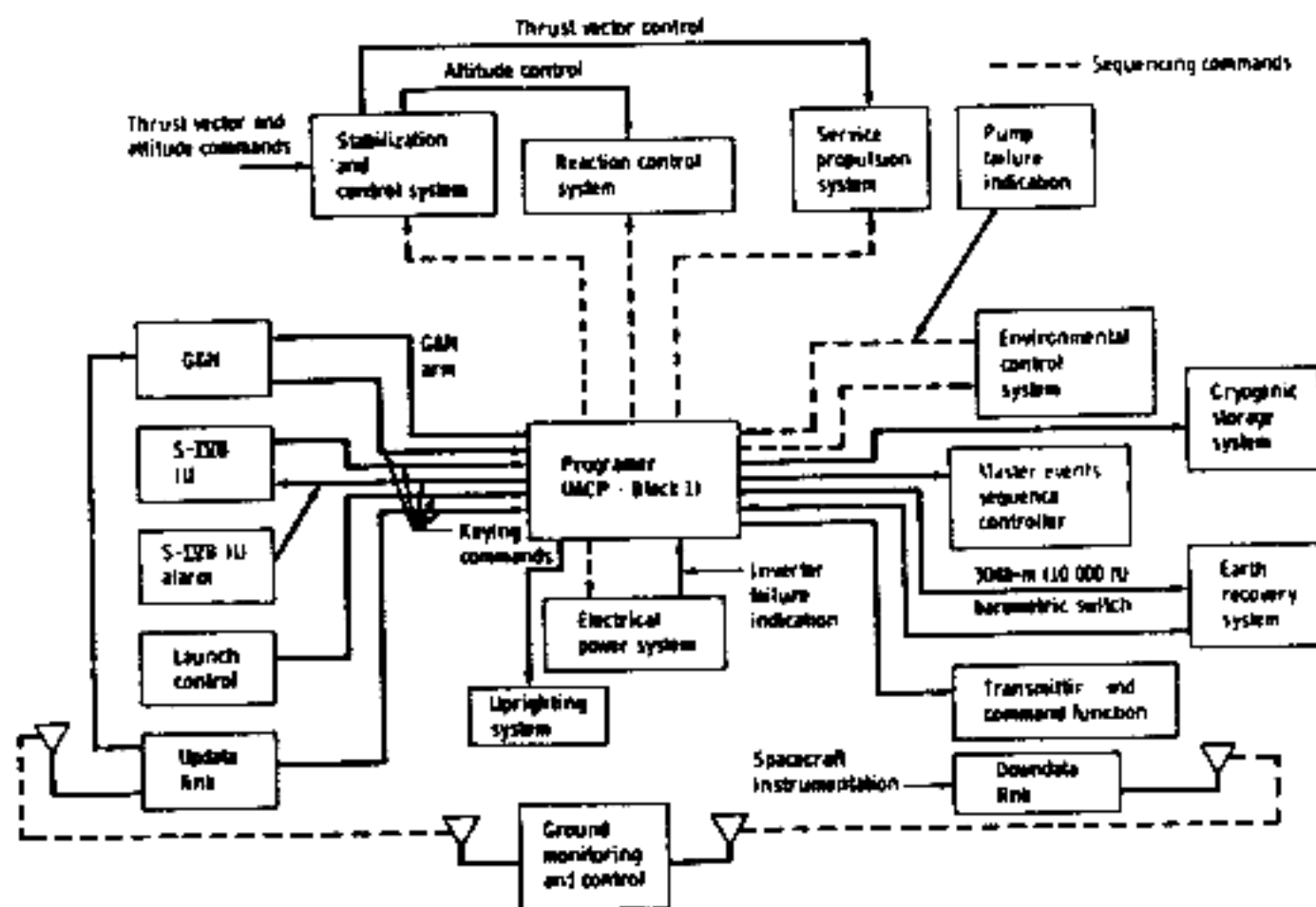
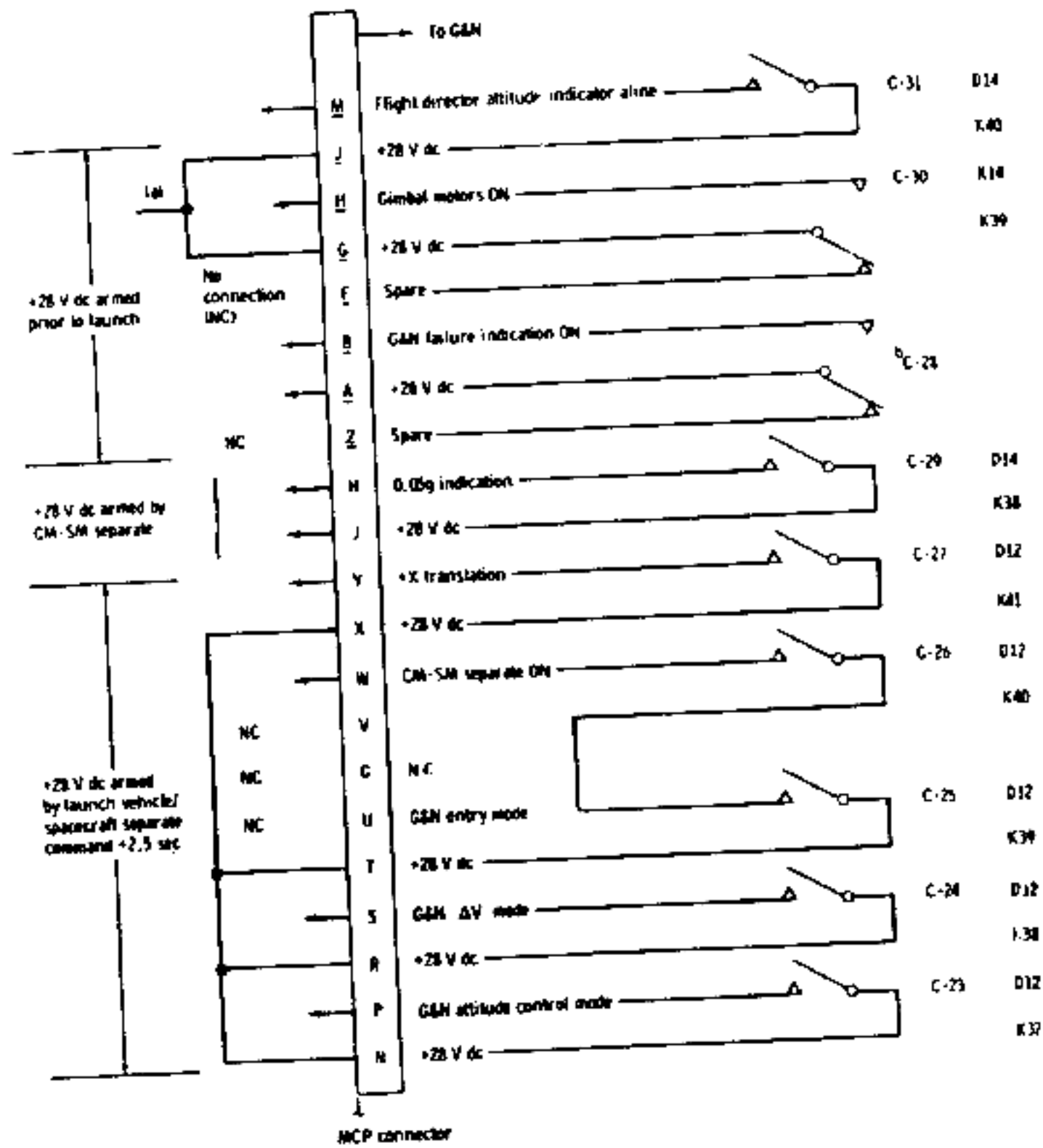

Figure 4. - Block diagram of the MCP.

A diagram of the logic circuitry of the interface between the MCP and the launch control and ground support equipment (GSE) is shown in figure 7. This interface provided launch-control personnel with the capability to disarm the pyrotechnics, switch off the logic buses, and operate the onboard flight recorders while the spacecraft and launch vehicle were stacked at the launch site. The program reset signal of this control interface allowed launch-control personnel to start the MCP; that is, to reset all latching relays and prepare the MCP logic circuit for lift-off.



^a ON except after launch escape system abort or G&N fail.
^b The C-28, et cetera, nomenclature refers to relays associated with the Apollo guidance computer.

Figure 5. - Diagram of the G&N system connector interface with the SCC.

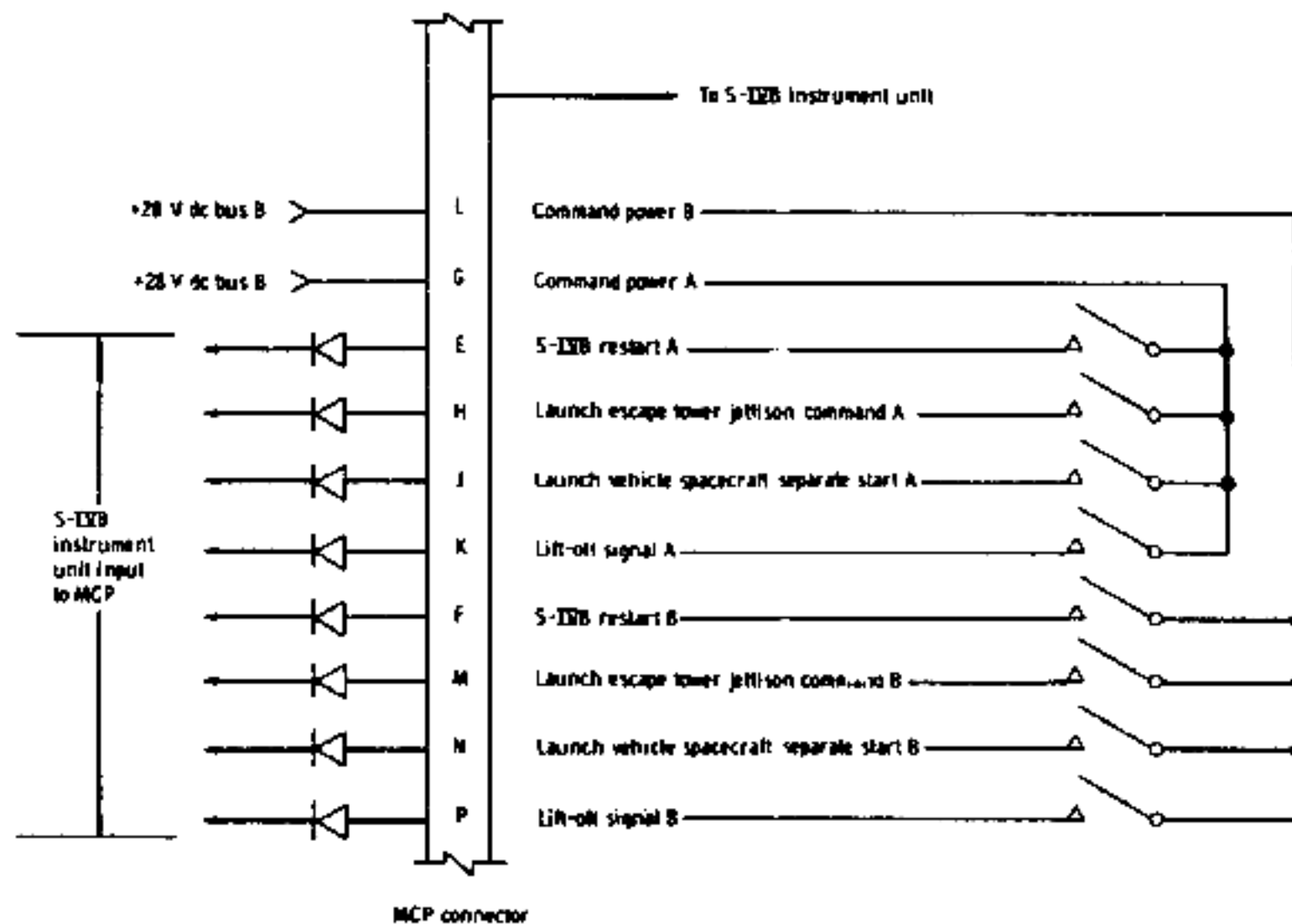

Figure 6. - Diagram of the S-IVB IU interface with the SCC.

Sequencing To Accomplish Mission Requirements

After the MCP received the sequence keying commands from the input interfacing systems, the programmer processed these commands through the internal relay-logic and time-delay circuitry to provide the proper output switching signal to the required spacecraft system (e. g., the flight qualification recorder).

The Apollo 4 mission events (summarized in table I) are typical of the other missions and are used as an example. The planned times for certain mission events, listed in the Apollo 4 Mission Report, varied as much as 28 seconds from the times that were predicted (table I) less than 3 months before the flight. These changes in the planned times of certain mission events demonstrate the dynamics of mission planning and the necessity of designing hardware with the flexibility needed to accomplish these mission changes.

During the Earth-intersecting coast phase of the Apollo 4 mission, the CSM was alined in an attitude to achieve a specific thermal gradient (cold soak) across the heat shield. This spacecraft orientation was maintained for approximately 4.5 hours before the CSM was reoriented for the second engine firing of the service propulsion system (SPS). The sequence of events leading up to and including the second SPS engine ignition will be discussed as an example. The detailed sequences to be discussed are between

time references t_B and t_C and between t_4 and t_6 listed in table I and described in table II. These sequences, which were initiated by the G&N system computer, are not listed as specific times (hours, minutes, and seconds) but are given as reference symbols (t_A , t_B , t_2 , etc.). The detailed software programs for the G&N-system computer established these specific times for the various missions.

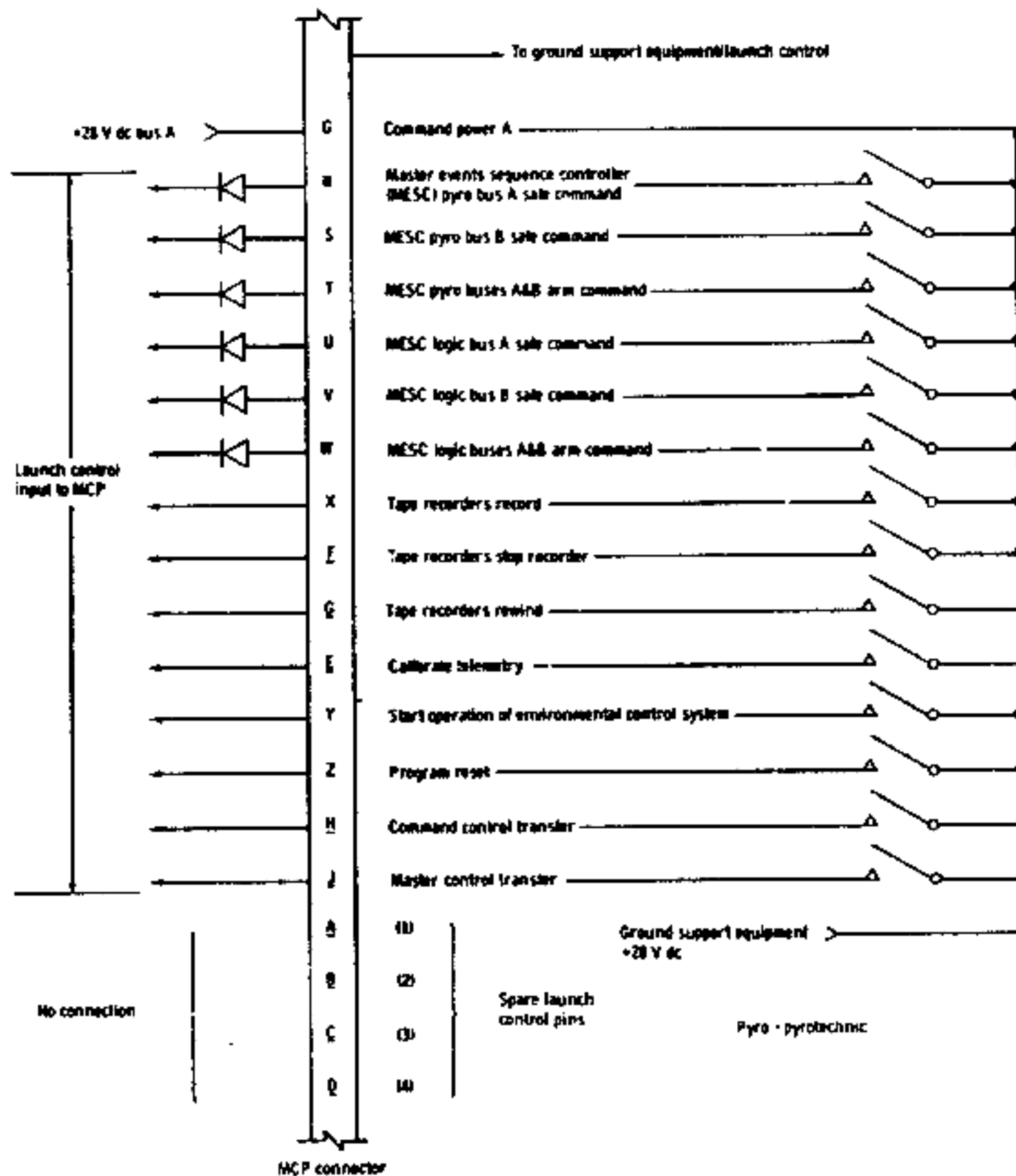

Figure 7. - Diagram of launch control and GSE interface with the SCC.

TABLE I. - APOLLO 4 MISSION DISCRETE EVENTS SUMMARY

Event	Planned time from lift-off, hr:min:sec (a)	Actual time, hr:min:sec
Saturn V ascent to orbit		
Guidance reference release	00:00:16.70	--
Lift-off	00:00:00.00	00:00:00.263
Saturn IC (S-IC) inboard engine cut-off	00:02:15.50	00:02:15.52
S-IC outboard engine cut-off	00:02:32.40	00:02:30.77
Saturn II (S-II) engine ignition	00:02:35.20	--
S-IC interstage jettison	00:03:04.35	--
Launch escape system jettison	00:03:08.35	--
S-II engine cut-off ^b	00:08:39.55	00:08:39.76
S-IVB engine ignition ^b	00:08:44.05	00:08:40.72
S-IVB engine cut-off ^b	00:11:05.40	00:11:05.64
Earth parking orbit		
Start Earth parking orbit	00:11:15.60	00:11:15.6
Start second orbit revolution	01:38:20.00	--
Second S-IVB firing		
S-IVB engine ignition ^b	03:11:54.50	03:11:26.6
S-IVB engine cut-off ^b	03:17:12.53	03:16:26.3
Coast to first service propulsion system (SPS) firing		
Begin reorientation to cold-soak attitude	03:17:27.71	--
End of reorientation to cold-soak attitude	03:20:42.81	--
CSM/S-IVB separation	03:27:14.43	03:26:28.2

^aThe planned times given are taken from AS-501 Spacecraft Operational Trajectory, Volume I—Trajectory Description, August 25, 1967.

^bRefers to guidance signal.

TABLE I. - APOLLO 4 MISSION DISCRETE EVENTS SUMMARY - Continued

Event	Planned time from lift-off, hr:min:sec (a)	Actual time, hr:min:sec
Begin reorientation to first SPS ignition attitude	03:27:22.73	--
End of reorientation to first SPS ignition attitude	03:27:51.81	--
First SPS firing		
SPS engine ignition ^b	03:28:52.73	03:28:06.6
SPS engine cut-off ^b	03:29:18.93	03:28:22.6
Earth intersecting coast		
Begin reorientation to cold-soak attitude	03:29:24.68	--
End of reorientation to cold-soak attitude	03:29:53.76	--
Apogee	05:49:04.32	--
Begin reorientation to second SPS ignition attitude	08:01:36.75	= t _B (note c)
End of reorientation to second SPS ignition attitude	08:02:01.05	= t _C (note c)
Reaction control system (RCS) thrusters on	08:14:40.42	--
Second SPS firing		
Second SPS engine ignition ^b	08:15:10.42	08:10:54.8 = t ₄ (note c)
Second SPS engine cut-off ^b	08:19:34.40	08:15:35.4 = t ₈ (note c)

^aThe planned times given are taken from AS-501 Spacecraft Operational Trajectory, Volume I -- Trajectory Description, August 25, 1967.

^bRefers to guidance signal.

^cTable II provides additional information.

TABLE I.- APOLLO 4 MISSION DISCRETE EVENTS SUMMARY - Concluded

Event	Planned time from lift-off, hr:min:sec (a)	Actual time, hr:min:sec
Preentry sequence		
Begin reorientation to CM/SM separation attitude	08:20:12.97	--
End of attitude orientation, coast to CM/SM separation	08:20:54.01	--
CM/SM separation	08:22:07.85	08:18:02.8
Start CM attitude orientation for entry	08:22:12.85	--
End of attitude orientation, coast to entry	08:22:36.03	08:18:06.28
Atmospheric entry		
0.05g indication	--	08:19:56.28
121 920-m (400 000 ft) altitude	08:23:35.02	--
Enter S-band blackout	08:23:57.00	--
Enter C-band blackout	08:24:01.00	--
Exit C-band blackout	08:25:55.00	--
Exit S-band blackout	08:26:19.00	--
Enter S-band blackout	08:30:15.00	--
Exit S-band blackout	08:31:47.00	--
Drogue-parachute deployment	08:35:39.00	08:31:18.6
Main-parachute deployment	08:36:27.00	--
CM landing	08:41:25.00	--

^aThe planned times given are taken from AS-501 Spacecraft Operational Trajectory, Volume I — Trajectory Description, August 25, 1967.

TABLE II. - NOMINAL MISSION SEQUENCE OF EVENTS
FOR SECOND SPS FIRING

Time reference	Initiated by —	MCP function	Function.	Output to —
Reorientation to second SPS ignition attitude				
t_A	G&N	X	Monitor mode OFF and G&N attitude control mode ON	SCS ^a
t_B	G&N		Initiate pitch maneuver	SCS
t_C	G&N		Complete pitch maneuver	SCS
t_D	G&N	X	Flight director attitude indicator aline ON	SCS
t_E	G&N	X	Flight director attitude indicator aline OFF	SCS
Second SPS thrust maneuver				
t_0	G&N	X	G&N attitude control mode OFF and monitor mode ON	SCS
t_1	G&N	X	Monitor mode OFF and G&N ΔV mode ON	SCS
t_2	G&N	X	Positive-X translation ON	SCS
t_3	G&N	X	Gimbal motors ON	MCP
	MCP	X	Entry batteries to main dc buses	EPS ^b
	MCP	X	Flight qualification recorder ON	T/C ^c
	MCP	X	Prepilot valve A ON	SPS
	MCP	X	Data storage equipment recorder ON	T/C
	MCP	X	Prepilot valve B ON	SPS
$t_3 + 1.0$ sec	MCP	X	Yaw 1 gimbal motor start	SPS

^a Stabilization and control system.

^b Electrical power system.

^c Transmitting and control function.

TABLE II. - NOMINAL MISSION SEQUENCE OF EVENTS
FOR SECOND SPS FIRING - Concluded

Time reference	Initiated by —	MCP function	Function	Output to —
Second SPS thrust maneuver - Concluded				
$t_3 + 1.5$ sec	MCP	X	Yaw 1 gimbal motor ON	SPS
	MCP	X	Pitch 1 gimbal motor start	SPS
$t_3 + 2.0$ sec	MCP	X	Pitch 1 gimbal motor ON	SPS
	MCP	X	Yaw 2 gimbal motor start	SPS
$t_3 + 2.5$ sec	MCP	X	Yaw 2 gimbal motor ON	SPS
	MCP	X	Pitch 2 gimbal motor start	SPS
$t_3 + 3.0$ sec	MCP	X	Pitch 2 gimbal motor ON	SPS
t_4	G&N		SPS thrust ON (second firing)	SCS
t_5	G&N	X	Positive-X translation OFF	SCS
t_6	G&N		SPS thrust OFF	SCS
	G&N	X	Gimbal motors OFF	MCP
$t_6 + 3.0$ sec	MCP	X	Gimbal motors OFF	SPS
	MCP	X	Remove entry batteries from main buses	EPS
	MCP	X	Select third gimbal position set	SCS
	MCP	X	Prepilot valve A OFF	SPS
	MCP	X	Prepilot valve B OFF	SPS
t_7	G&N	X	G&N ΔV mode OFF and monitor mode ON	SCS

The MCP was designed with the specification that the initiation times for particular keying and sequencing commands for performing various mission functions could be changed from mission to mission. However, the detailed integrated sequence of events to accomplish any particular mission function would remain consistent for all missions. Table II lists the functions required to reorient the spacecraft to the second SPS engine ignition attitude and the functions required to initiate and complete the second thrust maneuver. The MCP time delays are shown in the time-reference column. For example, " $t_3 + 1.0$ sec" indicates that the "yaw 1 gimbal motor start" signal from the MCP to the SPS gimbal actuator motor occurred 1.0 second after the G&N system computer had given the "gimbal motors ON" signal (t_3) to the MCP. The time-delay units were hardwired, potted plug-in modules that were hermetically sealed in a metal case. Several time-delay selections were available for a given module base connection size. Because of the high-start-current requirements of the motors, the gimbal motors were turned on at 0.5-second intervals to prevent an electrical overload. Table II gives a function-by-function description of the spacecraft system activity required to perform an SPS thrust maneuver. A similar functional listing can be obtained for all the required mission events, including abort sequencing.

At time t_3 , the MCP turned on the flight qualification recorder and the data-storage-equipment recorder. The sequences of events that were considered the most critical or of the highest priority and that were to be recorded varied significantly from mission to mission. The recorders and cameras had a limited tape and film capacity; and timed on-off sequences, which varied significantly from mission to mission, were necessary to obtain only the most important data. These changes in sequence times required MCP hardware changes. Usually, the times varied so much that different connector interface circuits had to be selected for the keying commands (e.g., a command for a second SPS firing gimbal motors off instead of a command for S-IVB/spacecraft separation). These MCP hardware modifications were costly in terms of money and schedule time, requiring new engineering drawings, specification revisions, test equipment modifications, recertification of the test equipment, and reacceptance testing of the flight hardware. In future manned or unmanned developmental flight programs, strong emphasis should be given to the developmental instrumentation interface with the spacecraft systems. For launch vehicles or spacecraft that contain flight computers, the instrumentation used to monitor flight events during the developmental program should be designed so that the changes of instrumentation sequences from mission to mission can be placed in the erasable portion of the computer memory. If this procedure were followed, the sequences could be quickly and cheaply modified in real time.

Real-Time Commands for Ground Control

The MCP, through the GCC unit, provided the switching logic circuitry, the relays, the relay drivers, and the required spacecraft system interface and had the capability to process 77 ground-commanded signals received by the spacecraft through the digital updata link. This technique provided a backup performance capability to the spacecraft by using ground support personnel and their flight control consoles to provide the updata-link signal commands. A list of the titles and number codes of possible real-time commands is given in table III. The number codes correspond to the appropriate flight control console switches in the Mission Control Center for the uplinked transmissions.

TABLE III. - REAL-TIME COMMANDS

Real-time command number	Title
01	Abort light (system A) ON ^a
00	Abort light (system A) OFF ^a
07	Abort light (system B) ON ^a
06	Abort light (system B) OFF ^a
02	Fuel cell 1 purge
03	Fuel cell 2 purge
04	Fuel cell 3 purge
05	Reset real-time command numbers 02 to 04
10	Lifting entry
11	Direct thrust ON
12	Direct thrust OFF
13	Reset real-time command numbers 10 to 12
14	Positive pitch direct rotation
15	Negative pitch direct rotation
16	Positive yaw direct rotation
17	Negative yaw direct rotation
20	Positive roll direct rotation
21	Negative roll direct rotation
22	Direct ullage
23	Reset real-time commands 14 to 22
24	Propellant OFF SM quad A
25	Propellant OFF SM quad B
26	Propellant OFF SM quad C
27	Propellant OFF SM quad D
32	Propellant ON SM quad A
33	Propellant ON SM quad B

^aNot used.

TABLE III.- REAL-TIME COMMANDS - Continued

Real-time command number	Title
34	Propellant ON SM quad C
35	Propellant ON SM quad D
40	Launch escape tower jettison
41	G&N fail
42	G&N fail inhibit
43	Reset real-time command numbers 41 to 42
44	Roll rate backup
45	Pitch rate backup
46	Yaw rate backup
47	Flight director attitude indicator align
50	Reset real-time commands 44 to 47
51	Negative-Z antenna ON (very-high-frequency (vhf) scimitar only)
52	Positive-Z antenna ON (vhf scimitar only)
54	Roll A and C channel disable
55	Roll B and D channel disable
56	Pitch channel disable
57	Yaw channel disable
60	Reset real-time command numbers 54 to 57
61	CM and SM separation
62	Update link S-band receiver select
63	Update link ultrahigh-frequency receiver select
64	Hydrogen tank 2 heater fan ON
65	Oxygen tank 2 heater fan ON
66	Hydrogen tank 1 heater fan ON
67	Oxygen tank 1 heater fan ON
70	Reset real-time command numbers 64 to 67

TABLE III. - REAL-TIME COMMANDS - Concluded

Real-time command number	Title
71	Launch escape tower abort and MCP separation
73	Spare
74	C-band OFF
75	C-band ON (2 pulse)
76	vhf transmitter OFF
77	vhf transmitter ON

Real-time commands 14 to 21, 23, and 54 to 60 were to be used to control the spacecraft attitude if the automatic attitude control provided by the G&N system had not functioned properly. If this malfunction had occurred, the automatic channels to the reaction control system (RCS) could have been disconnected by real-time commands 54 to 60, and the direct rotation commands, real-time commands 14 to 21, could have been transmitted. The direct rotation commands required that the ground controllers transmit the time interval necessary to achieve the desired spacecraft attitude. For example, if the G&N system had failed, the second SPS firing sequence could have been accomplished by ground controllers using real-time commands according to the following sequence.

1. Send real-time command 41, "G&N fail."
2. Use real-time commands 14 to 21 to position the vehicle to the proper firing attitude.
3. Send real-time command 11, "direct thrust ON," at the desired firing time to automatically start the gimbal motors in sequence and to initiate the firing.
4. Monitor the spacecraft trajectory by using the Mission Control Center real-time tracking data.
5. Send real-time command 12, "direct thrust OFF," at some predetermined velocity point or at the violation of a limit line on the trajectory plot.
6. The vehicle probably would be oriented for CM and SM separation by the real-time commands cited in step 2. Such a probability would be consistent with the example that the G&N system had failed; therefore, additional mission objectives would not be attempted.

7. Send real-time command 61, "CM and SM separation," to arm the master events sequence-controller (MESC) logic circuitry, to arm the pyrotechnic devices, and to initiate the separation sequence.

8. The vehicle would be oriented for entry.

The advantages of retaining a degree of real-time ground control of the spacecraft would have been demonstrated if a spacecraft system failure had actually occurred during one of the flights. If the G&N system had malfunctioned, some useful heat-shield data at the required high-entry velocities still could have been obtained. Several combinations of spacecraft sequencing and control, other than that of the G&N system malfunction, could be accomplished by real-time commands. The flight operation plans and the launch rules for each mission furnish a description of the many possible alternate mission modes. Several real-time-command numbers are intentionally omitted from table III. The following real-time commands were deleted by the NASA before the Apollo 4 and 6 missions.

<u>Number</u>	<u>Title</u>
30	CM RCS system A propellant OFF
31	CM RCS system B propellant OFF
36	CM RCS system A propellant ON
37	CM RCS system B propellant ON
53	G&N antenna switching

Backup 0.05g Acceleration Sensor

Several significant mission events were required between the entry phase and the landing (table IV). The sensing of the point of atmospheric entry (the point at which 0.05g deceleration is reached, which occurred at an altitude of approximately 88 400 meters (290 000 feet) is a critical mission event for recovery of the spacecraft. The primary determination of the entry point (0.05g) was made by the G&N system, and a redundant 0.05g signal was provided in case the G&N system failed to provide this signal or in case the G&N system had failed earlier in the mission. This redundant signal was produced by accelerometers in the ADS unit of the MCP. Table IV shows the MCP transferring the 0.05g signal from the G&N system to the stabilization and control system (SCS) at t_0 . The importance of accurately determining the point at which 0.05g was reached cannot be overemphasized, because, after this point is passed, the method of controlling the spacecraft with the RCS thrusters is changed. The pitch and yaw attitude control was inhibited by the SCS, and the spacecraft was steered by using the RCS thrusters to roll the spacecraft about an offset center of gravity. Other important spacecraft systems (e.g., the Earth-landing system (ELS)) were also activated when the 0.05g point was sensed. Thus, the MCP performed an important function on unmanned flights as the redundant deceleration indicator.

TABLE IV.- NOMINAL MISSION SEQUENCE OF EVENTS FROM ENTRY TO LANDING

Time reference	Initiated by —	MCP function	Function	Output to —
Entry phase				
t_0 (about 28 min before landing)	G&N	X	0.05g ON \approx 88 400 m (\approx 290 000 ft)	MCP
	MCP	X	0.05g signal (backed up by the MCP 0.05g backup function)	SCS
	MCP	X	Earth landing system (ELS) activate A	ELS
	MCP	X	ELS activate B	ELS
	MESC		7620-m (25 000 ft) barometric switch armed	ELS
	MCP	X	Switch to negative-Z antenna	T/C
7620-m (25 000 ft) altitude				
	ELS		7620-m (25 000 ft) barometric switch activated	MESC
	MESC		SCS/RCS enable OFF	RCS
	MESC		Apex cover jettisoned	CM
	ELS		Drogue-parachute deployment (reefed)	CM
	ELS		Drogue-parachutes disreefed	CM
	ELS		Arm 3658-m (12 000 ft) barometric switch	ELS
3658-m (12 000 ft) altitude				
t_0 (maximum of 13 min before landing)	ELS	X	3658-m (12 000 ft) barometric switches A and B	MCP
$t_0 + 20$ sec	MCP	X	Start landing backup 14-min timer	MCP
	MCP	X	Connect C battery to flight and postlanding (F&PL) bus	EPS
$t_0 + 270$ sec	MCP	X	RCS fuel dump activate A	RCS
	MCP	X	RCS fuel dump activate B	RCS
	MCP	X	Arm landing switch	MCP
	MCP	X	vhf recovery beacon ON	T/C
	MCP	X	vhf survival beacon ON	T/C
	MCP	X	RCS purge activate A	RCS
	MCP	X	RCS purge activate B	RCS
	MCP	X	Impact landing	RCS

Sequencing Postlanding Recovery Aids

Another function of the MCP was to sequence the postlanding recovery aids for the unmanned missions. The correct performance of these functions was necessary to ensure the recovery of the spacecraft after landing was successfully achieved. The sequence of events after landing (table V) was initiated by the impact of the spacecraft on the water. The impact was sensed by triply redundant switch accelerometers in the ADS unit of the MCP. The MCP was also required to test and certify the uprighting system of the spacecraft before a manned flight. The ADS unit contained triply redundant attitude indicators that could sense whether the spacecraft was floating apex up (stable I) or apex down (stable II). If a stable II signal had been indicated by the attitude switches (table V), logic circuits in the SCC would have relayed a signal to the uprighting system to inflate the flotation bags.

TABLE V. - NOMINAL MISSION RECOVERY SEQUENCE OF EVENTS

[All events are MCP functions initiated by the MCP.]

Time reference	Function	Output to —
Nominal events		
t_0	Impact landing	
	Main-parachute disconnect A	ELS
	Main-parachute disconnect B	ELS
	Arm attitude indicator	MCP
	Connect entry batteries to F&PL bus	EPS
	Connect auxiliary batteries 1 and 3 to F&PL bus	EPS
	Connect auxiliary batteries 2 and 3 to F&PL bus	EPS
$t_0 + 11 \text{ sec}$	Remove entry batteries from main buses	EPS
	Deploy high-frequency (hf) recovery antenna (stable I only)	T/C
	MESC logic bus A safe	MESC
	MESC logic bus B safe	MESC
	Flashing light ON	T/C
	hf transceiver ON (stable I only)	T/C
	Circuit breaker 45 OPEN	

TABLE V. - NOMINAL MISSION RECOVERY SEQUENCE OF EVENTS - Concluded

[All events are MCP functions initiated by the MCP.]

Time reference	Function	Output to —
Nominal events - Concluded		
$t_0 + 12 \text{ sec}$	Auxiliary battery 1 OFF auxiliary bus A	EPS
	Auxiliary battery 3 OFF auxiliary buses A and B	EPS
	Auxiliary battery 2 OFF auxiliary bus B	EPS
	MESC pyrotechnic bus A safe (stable I only)	MESC
	MESC pyrotechnic bus B safe (stable I only)	MESC
Events for stable I landing		
t_1	Flotation pumps OFF hf transceiver ON Deploy hf recovery antenna	URS ^a T/C T/C
$t_1 + 1.0 \text{ sec}$	MESC pyrotechnic bus A safe MESC pyrotechnic bus B safe	MESC MESC
Events for stable II landing		
t_0	hf transceiver OFF	T/C
$t_0 + 60 \text{ sec}$	Flotation pumps ON	URS
	Flotation bag 1 fill	URS
$t_0 + 360 \text{ sec}$	Flotation bag 1 OFF	URS
	Flotation bag 2 fill	URS
$t_0 + 660 \text{ sec}$	Flotation bag 2 OFF	URS
	Flotation bag 3 fill	URS
$t_0 + 960 \text{ sec}$	Flotation bag 3 OFF	URS
	Flotation pump OFF	URS

^aUprighting system.

DESIGN USING EXISTING TECHNOLOGY

The critical development schedules for the MCP required that existing electronic technology be used. Components that had been previously qualified on other missile or space programs were selected whenever practicable.

Spacecraft Command Controller

The MCP block diagram in figure 4 shows the Apollo system interfaces required by the MCP. The SCC unit of the MCP provided the logic capability needed to accomplish the interface and event-sequencing requirements. The event-sequencing and switching functions for the unmanned flights were accomplished by the use of relays. These hermetically sealed microminiature general-purpose relays, which had an all-welded construction, were used extensively in the logic and switching circuitry. The relays operated at 28 V dc and had a 2-, 3-, or 10-ampere current rating.

The redundancy requirements of the MCP were classified into four categories.

1. **Simplex (not redundant)** — The MCP output or real-time-command function may fail either ON or OFF because of a single MCP component failure (fig. 8(a)).

2. **Dual series (redundant)** — The MCP output or real-time-command function shall not fail ON as a result of any single MCP component failure (fig. 8(b)).

3. **Dual parallel (redundant)** — The MCP output or real-time-command function shall not fail OFF as a result of any single MCP component failure (fig. 8(c)).

4. **Dual series, triply parallel (redundant)** — The MCP output or real-time-command function must respond correctly in the event of a single MCP component failure (fig. 8(d)).

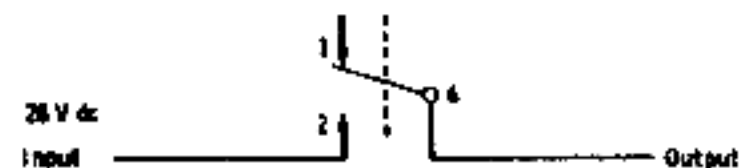

(a) Simplex (not redundant).



(b) Dual series (redundant).

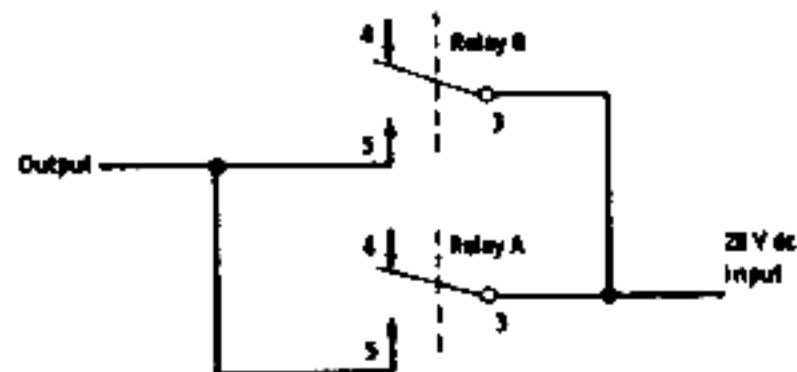

(c) Dual parallel (redundant).

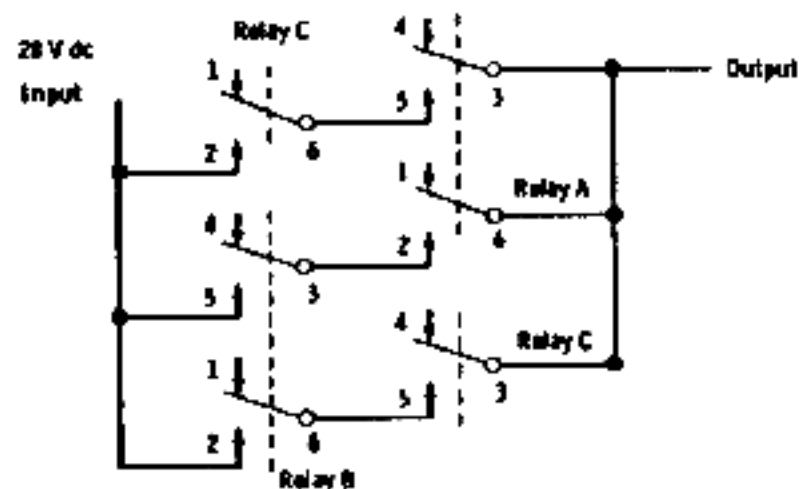

(d) Dual series, triply parallel (redundant).

Figure 8. - Circuit logic and switching relays.

The redundancy requirements for the MCP design were established by using these four categories. A request for a definition of the requirements of the system interface was submitted to the appropriate engineering design groups, and specific redundancy requirements were obtained on an event-by-event basis for numerous potential missions. The design of the MCP was then established consistent with these mission redundancy requirements.

The redundancy options that were used in the MCP are shown in figure 8. Examples of equivalent redundancy could also be illustrated within the MCP, showing the use of time delays, capacitors, diodes, et cetera. The relays are used for illustration because they represent the majority of the components in the MCP.

The circuits in figure 8 are shown with relay contacts configured in the normally open state. Similar redundant configurations are used with the relay contacts in a normally closed state. Both momentary and latching relays were used in the MCP design. Momentary relays remain switched into the changed-state configuration only as long as the switching signal is applied to the solenoid. Latching relays remain in the switched configuration until an additional reset switching signal is applied to the reset solenoid of the relay.

A triply redundant grounding network was used throughout the cable-harness and panel-harness assemblies (fig. 9) to provide electrical grounds for the MCP. This grounding scheme was important in accomplishing the bench tests and spacecraft tests that verified the redundant components within the MCP. During tests, these grounds (G_1 , G_2 , and G_3) were alternately cycled (opened and closed) or cycled in combinations (G_1G_3 , G_2G_3 , or G_1G_2) to isolate and verify the operation of specific redundant paths. For example, in figure 8(d), assume relay A operates with ground G_1 ; relay B with ground G_2 ; and relay C with ground G_3 . The redundant paths would be verified as follows.

1. Make contact between grounds G_1 and G_2 , and leave G_3 open.
2. With the proper signal to the relay solenoids, relays A and B close their contacts.
3. Step 2 verifies the center path shown in figure 8(d). The top and bottom circuits remain open because relay C has no ground to complete its circuit and does not close.
4. Make contact between grounds G_2 and G_3 , and leave G_1 open.
5. Relays B and C close their contacts, and relay A remains open.
6. Step 5 verifies the bottom path shown on figure 8(d). The two top paths remain open because relay A has no electrical ground to activate its solenoid circuits and the contacts do not close.
7. Relay A in the middle path does not have its contacts failed in a closed position in step 3, because in step 6 the middle path opened. If, in step 6, the middle row of contacts had not opened, the failure of relay A in a closed position would have been indicated.



Figure 9.- Cable assembly wire harness.

This method can be continued until each redundant function is verified. This redundancy was an important part of the Apollo Program, because the proper functioning of each redundant circuit path had to be verified just before the spacecraft was launched. The procedure of checking redundant circuitry before launch was used for the Mercury spacecraft and was continued for the Apollo spacecraft. In general, this verification of redundant circuit paths was a simple task for the Apollo spacecraft, because most systems were designed to be dually redundant (system A and system B). The power could be removed from either system to verify the proper functioning of the companion system. However, checking the redundant circuitry in the MCP became a difficult and tedious job because of the many complex series-parallel circuit paths.

As shown in figure 2, the SCC used 19 printed wiring boards (control assemblies). The detailed logic circuits, relays, time-delay circuits, and other components were plugged into these control assemblies; the components of this circuitry were standardized and interchangeable. For example, a 3-ampere latching relay could be interchanged with a 3-ampere momentary relay, or a 15-second time-delay device could be interchanged with a 60-second time-delay device (figs. 10 and 11). Great care had to be taken by the manufacturing personnel when removing a component that had previously been mounted and soldered to the printed wiring board; otherwise, the metallic track could be lifted from the board or damaged. The control assemblies used for the various MCP systems were also standardized and interchangeable. For example, control assembly 6 in MCP system 2 and the similar control assembly in MCP system 4 could be interchanged to resolve a problem with solder closeout relays.

The SCC had 15 connectors to meet the various interface requirements and to provide sufficient test points for ground tests. The unit had a ground-shortening connector and three GSE connectors that were instrumented for the box-level bench tests. The internal grounds could be automatically applied and removed while the operation of various components was being verified on the bench test console.

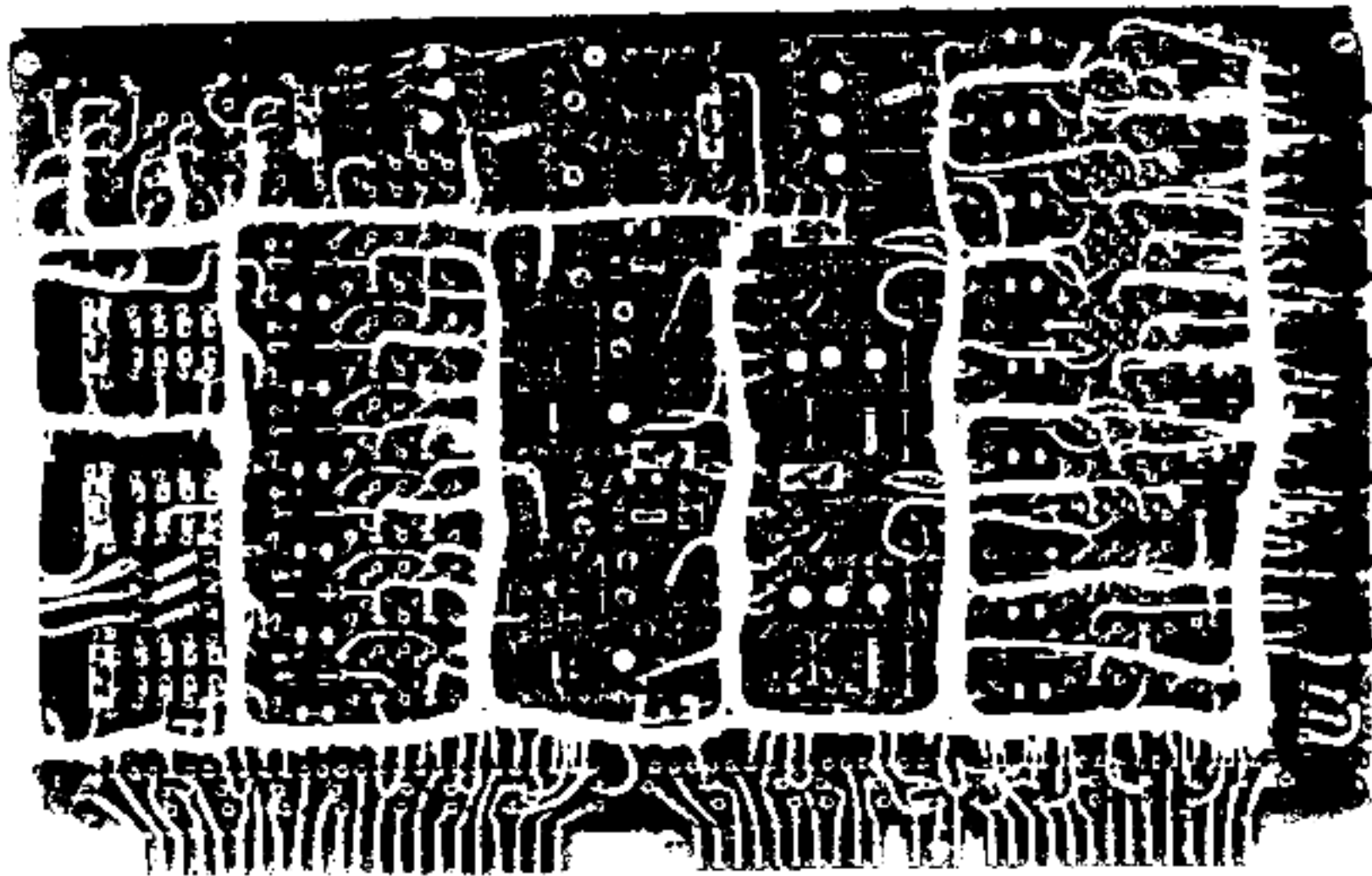

Figure 10. - Printed wiring board with components.

The importance of design flexibility must be emphasized. A description has been given of the increased flexibility obtained by interfacing the MCP with the G&N system for its input keying commands rather than by using fixed preset timers. However, this increased flexibility was limited. The interface connectors of the G&N system, the S-IVB IU, and the launch control and GSE (figs. 5 to 7 and 12) provided the MCP with capabilities for 15 different flight keying and sequencing commands, which could be modified for each mission, and 12 prelaunch keying commands. For approximately 120 different mission events, the MCP furnished the logic circuitry and internal time delays for switching the output to the interfacing systems at the correct mission times. The capabilities of the hardwired logic circuitry were not as flexible as had been desired. As mentioned previously, changes in the mission event sequence on-off times of interfacing hardware sometimes resulted in major MCP design changes.

The following are examples of MCP design changes resulting from changes in mission plans or in interfacing system requirements.

1. The planned trajectories for the Apollo 4 mission indicated a possibility of spacecraft skipout during the entry phase. The MCP originally had latching relays to prevent the loss of the 0.05g signal once it was obtained. During the Apollo 4 mission, the 0.05g signal could be obtained, lost during skipout, and then obtained again; therefore, the latching relay had to be replaced with a momentary relay.

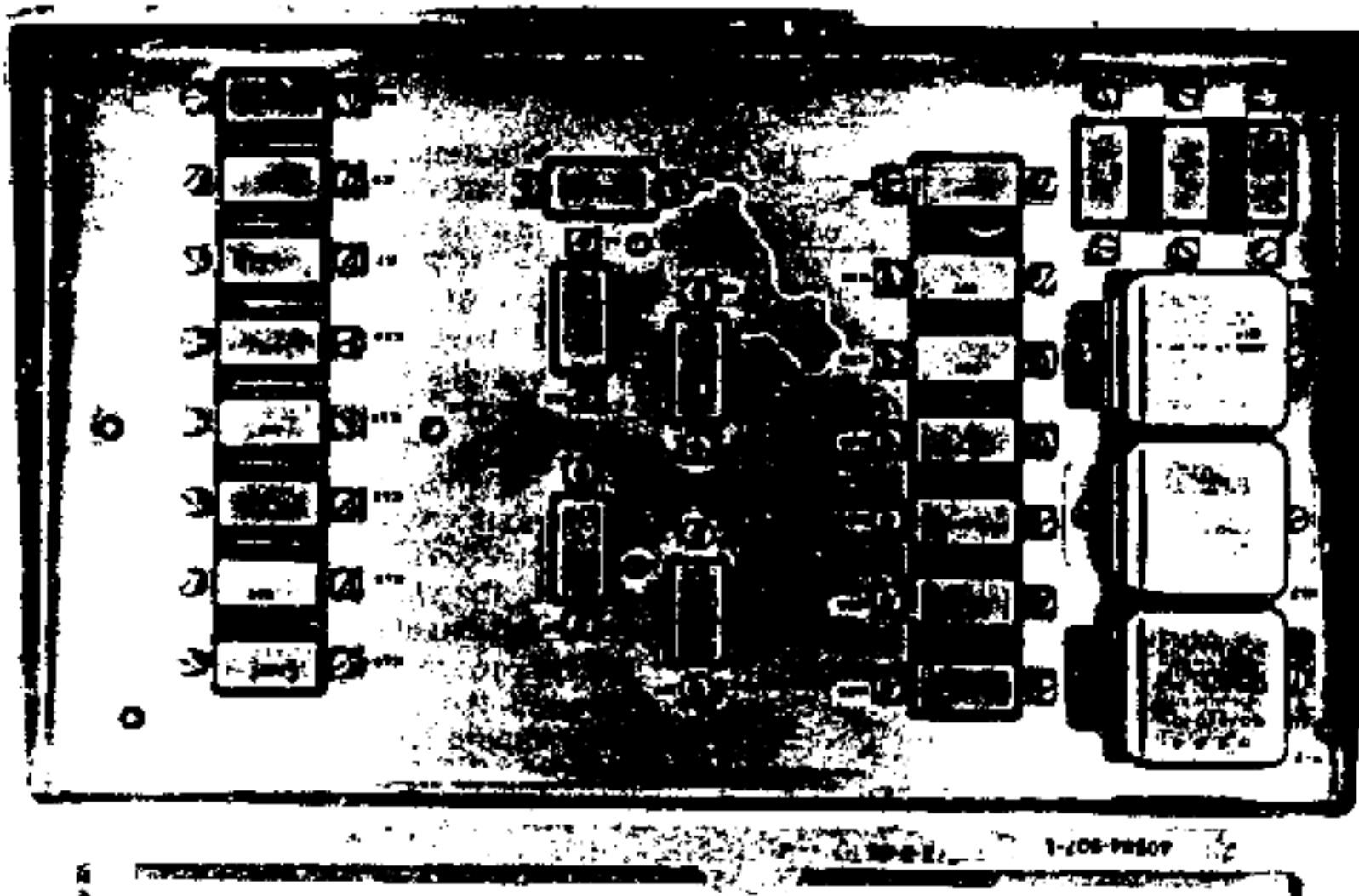

Figure 11.- Bracket showing relays and time-display mountings.

2. A 14-minute time delay was required after a sensing function (indicating an equivalent barometric pressure at a 3658-meter (12 000 foot) altitude) was added to the MCP. This function was an ELS backup to initiate cutting of the parachute shrouds 5 to 10 minutes after landing.

3. The gimbal motor on-off times were changed from mission to mission to prevent the actuator clutches from overheating.

4. A time delay was added in the MCP to prevent damage to the high-frequency antenna by not allowing the antenna to deploy before the spacecraft was in an apex-up attitude in the water.

5. Before the mission, the SPS engine gimbal positions were predicted for each firing during the mission. These positions were preset in the MCP to prevent large gimbal position changes and large transients during the firing initialization. Each spacecraft had different center-of-gravity requirements at the various firing times; thus, each spacecraft required different gimbal position settings that necessitated modification of the MCP system.

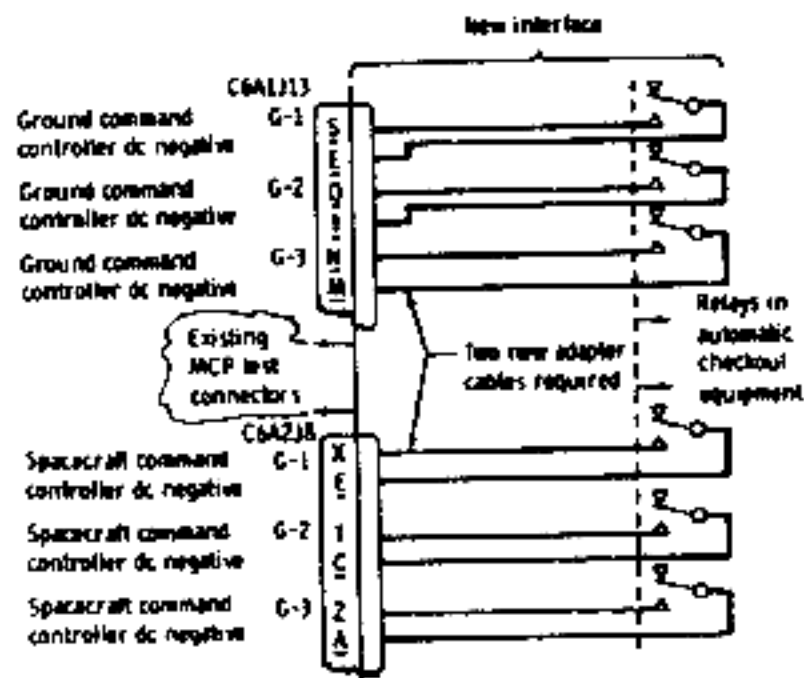

Figure 12. - Automatic checkout equipment interface requirements for the MCP redundancy test.

6. On-off sequences for the tape recorders and cameras were changed for each mission.

These few examples of the hardware changes made to the MCP indicate the flexibility required of a developmental flight system such as the MCP. For example, before the design of the MCP was complete, preplanning should have determined that the gimbal position settings would vary from mission to mission and that the hardware should be designed so that a technician could change the settings without opening the SCC. Whenever this unit was opened, a complete acceptance test was required. In future programs, the changeable characteristics of unmanned developmental flight tests should be recognized, and various flexible software methods of programming mission changes should be considered.

Ground Command Controller

The GCC unit of the MCP interfaced primarily with the updata link. This unit provided the switching-logic circuitry, the relays, the relay drivers, and other components for processing the 77 real-time ground-command signals originating at the flight control consoles in the Mission Control Center. The GCC design did not require the degree of flexibility required by the SCC. During the program, GCC changes were made to correct design problems and to eliminate certain capabilities, rather than to revise and redesign logic and interface circuitry. As previously discussed, five real-time commands were eliminated from the Apollo 4 and 8 missions; the GCC wiring associated with these commands was cut and stowed.

The GCC used component and wiring redundancy similar to that previously described for the SCC. The series-redundant circuitry (fig. 8) was the most commonly used circuit logic; however, parallel-redundant circuitry was used for processing the reset real-time command, and series-parallel-redundant circuitry was used for processing the abort command.

The GCC was designed to respond to minimum current inputs of 18 to 24 milliamperes with a pulse duration of 25 to 35 milliseconds from the updata link. Also, the unit was designed not to respond to current levels less than or equal to 28 milliamperes when pulse durations were less than or equal to 1 millisecond. Early electromagnetic interference (emi) tests at the factory showed that the GCC relay drivers were triggering on noise voltages, and resistor-capacitor filter networks had to be added to each relay driver. This design change was the most significant factor incorporated in the GCC. The general configuration of the GCC and the SCC is the same (fig. 2).

The reset real-time commands 05, 13, 23, 43, 50, 60, and 70 were necessary because, once the GCC relay driver received a minimum-value current pulse from the updata link, the associated latching relays were activated. The real-time command could be removed or canceled only by sending a reset command. Some real-time commands used momentary relays (e. g., positive-Z antenna ON). These momentary relays were on as long as the command was being transmitted and off at all other times. The use of latching relays saved the electrical power that would have been required to hold the relay solenoid in the activated state and amounted to considerable power savings for events that would be on for long periods.

Attitude and Deceleration Sensor

The ADS unit of the MCP performed the critical spacecraft recovery requirements during the entry, landing, and recovery phases of the mission. The ADS design (fig. 3) was simple, consisting of the following major components.

1. Three spring-mass impact switches (accelerometers) to sense the water impact during landing
2. Three pendulum-mass attitude indicators to sense stable I or stable II orientation of the spacecraft after landing
3. Two linear accelerometers to sense the 0.05g level during entry
4. A pivot shaft and pivot frame for ground test of the attitude indicators
5. Push-to-test switches for ground testing the 0.05g and landing accelerometers
6. A radio-frequency interference filter for the input power

Components of the ADS were used in the following order during a mission.

1. The 0.05g accelerometers were armed by a signal from the SCC at the time of CM and SM separation. These accelerometers were designed to trigger at decelerations of 0.1g to 0.5g, a higher deceleration value than the 0.05g value furnished by the G&N system. In June 1966, the 0.4g spread in the tolerance of the backup deceleration sensor was recognized as possibly causing a wide deviation between the actual and planned spacecraft landing points when the backup signal was used. A specific test was then added to the box-level acceptance test to measure and record the exact deceleration level of this sensor. For spacecraft 017, this deceleration value was $0.29g \pm 0.04g$ for initiating the backup 0.05g signal. The 0.05g signal would be automatically overridden by the ADS in case of a skipout trajectory. The $\pm 0.04g$ tolerance could not be discarded because the accelerometers were temperature sensitive and the precise flight temperatures were not defined. The trigger point was better defined, however, at an order of magnitude closer than the initial values.

2. The three impact switches were armed by a signal relayed from the SCC when it sensed an altitude of 3658 meters (12 000 feet). The impact switches were designed not to trigger for impact pulses less than 4.7g and to trigger for values of approximately 5g and above. A push-to-test switch was provided for each impact switch for ground-test purposes.

--	--	--	--	--	--	--	--

3. The three attitude sensors were armed by the impact deceleration pulse. These sensors indicated stable I whenever the apex of the spacecraft was approximately $\pm 65^\circ$ from an upright position. When the apex of the spacecraft dropped below the 65° point, stable II was indicated by the sensors. Additional stable II functions of the sensors are given in table V. These attitude sensors could be tested in the spacecraft by loosening a hexagonal nut (fig. 3) and pivoting the sensors to effect a change in attitude signal.

TEST EQUIPMENT DESIGN

To meet the critical schedule requirements for the MCP qualification program and delivery, the contractor built three types of test equipment.

1. Manufacturing test sets
2. Manual test equipment (MTE)
3. Factory test equipment (FTE)

The manufacturing test sets were essential in the test activity associated with the production and assembly of the MCP control assemblies and printed wire networks. These test sets performed satisfactorily and supported the program in a timely manner.

The manual bench test console verified the operational status of each redundant component in the MCP during acceptance tests and other box-level tests. This bench console required that the input signal be switched manually at the times required by the test specifications. Groups of test points (e. g., 60 test points) were collectively monitored and, if no anomaly occurred, that test zone of redundant elements within the MCP was considered satisfactory. This MTE was similar to the equipment developed for the control programmer in spacecraft 009 (AS-201 mission) and was completed on November 14, 1965, in time to support the initial breadboard and early MCP prototype deliveries.

The MTE required approximately three times as long to complete a test run as did the automatic FTE; however, the MTE was sufficiently simple that the equipment could be certified and debugged in a timely manner and could be reconfigured for compatibility with changes in the flight hardware.

The automatic FTE was used for the postenvironmental functional tests and the MCP systems tests. This test equipment included the following.

1. A punched-tape reader to provide the input stimuli with the associated power supplies and signal-conditioning equipment
2. A series of internal logic circuits to control the switching and route the signals to the correct MCP area

--	--	--	--	--	--	--	--

3. A master clock to control the timing of the input signals and to provide a time comparison of the MCP response

4. An output load simulator to simulate interfacing systems loads

5. A printer to provide a tape record of the test events

The automatic FTE was primarily used to support qualification testing. A series of test tapes was prepared to support the environmental and postenvironmental functional tests as follows.

1. Environmental functional tests

a. Abbreviated-time simulated mission

b. Real-time simulated mission

c. Simulated abort and entry test

2. Postenvironmental functional tests

a. SCC functional test

b. GCC functional test

The requirement existed to automate the test and sequencing of the MCP while it was operating in the qualification-test environment. For example, during the vacuum test, an abbreviated-time simulated mission was performed while the MCP was in the 4-hour soak period of the vacuum environment. This requirement would have been impossible to achieve with the MTE because 48 hours would be required to sequence the MCP through all the programer functions manually. As a result, the requirement for a 4-hour vacuum soak would have to be exceeded. However, if the 4-hour vacuum soak were retained, the number of functions that could be manually sequenced would be so limited that only a small part of the MCP internal logic circuits could be tested.

The development and certification of the elaborate and complex FTE within the allotted schedule period caused considerable difficulty. A 4-month delay in the start of qualification of the GCC and SCC was generally attributed to problems in certifying the test equipment, the test specifications, and the test tapes. The schedule problem concerning certification of the FTE was related to the original design concept and the planned method of test. Considering the critical development schedules and the small number of unmanned systems to be delivered, the test equipment concept was much too complex and automation was overly emphasized.

Some specific problem areas in certifying the FTE included the following.

1. The test equipment did not verify functional paths within the MCP but checked out zones or groups of components; therefore, when a hardware change was incorporated in the MCP, a compatible change was difficult to incorporate in the related component group of the test equipment. Hardware changes also caused difficulty in updating the test specifications.

2. The tape reader had no reliable method of performing an internal verification or self-check. If a part of the tape message was missed, it was difficult to determine whether the problem was in the reader, the test equipment, the MCP, or some other system or component.

3. A reliable method was not developed to revise only specific sections of the test tapes to reflect hardware modifications. A reprogramming effort involving the entire test sequence seemed to be required. The test tape could not be cut and spliced; therefore, a new tape had to be generated to include the updated test section. As a result, the manpower requirements for test equipment programming were increased whenever the flight hardware was changed.

Because of these test equipment reprogramming delays, the FTE was not used to any great extent in supporting the MCP reacceptance tests following design modifications. The MCP redundancy test performed in the spacecraft provided a sufficient confidence level, and a systems-level functional acceptance test at the vendor was not required. The FTE was not reprogrammed and reconfigured to reflect the numerous MCP hardware changes. The engineering time was more efficiently used in actually performing the vendor box-level acceptance tests on the slower MTE than in preparing the automatic FTE to perform the MCP system-level test.

This experience could well be applied to the development of test equipment for future programs that have small quantities of deliverable end-items. For this type program, it seems preferable to expend the necessary engineering manpower in developing simple, flexible, manual, general-purpose test equipment and then to make the necessary allowances in delivery schedules. This approach appears preferable to expending the manpower in developing automated, complex, inflexible test equipment that would perform the test faster.

DEVELOPMENT SCHEDULES AND TEST PROGRAM

On June 25, 1964, the Apollo prime contractor was notified to develop a programmer with the capability to conduct the unmanned missions AS-201, AS-202, AS-501, and AS-502. The original schedule for the MCP installation into spacecraft 011 at the contractor's facility was January 13, 1966. The MCP development team had 19 months to design, build, test, and deliver the first flight system. The following paragraphs describe the most significant milestones concerning this development.

Breadboard and Prototype Development

The following schedule was achieved and indicates the compressed and critical nature of delivery milestones for the MCP.

<u>Delivery milestone</u>	<u>Date</u>
Design configuration freeze	October 28, 1965
Breadboard system delivery	November 1965
First prototype unit delivery	December 3, 1965
Second prototype unit delivery	December 17, 1965
First production unit delivery	January 14, 1966

Although the design configuration freeze was dated October 28, the following significant changes to the MCP design were approved on November 8; therefore, the configuration was not really frozen.

1. The on and off times of the flight-qualification tape recorders were changed and required wiring changes in the MCP.
2. The very-high-frequency antenna was switched differently for spacecraft 017 and 020, and additional wiring changes were required.

A maximum of 1 month was scheduled between delivery of the breadboard and the first prototype. The term "breadboard" cannot be used in the sense that the breadboard was a device to be tested and evaluated, with the results of the evaluations being fed back as design improvements. The rigorous acceptance tests and inspection-approval criteria that normally constrain development did not apply to this breadboard unit; therefore, the manufacturer could produce the unit as a working device to help in the test equipment development and certification. The prototype unit used the same production manufacturing and assembly techniques as the flight units. The first prototype was delivered to the spacecraft contractor for simulation testing and interface verification testing. The combined systems tests and simulations, using the first prototype unit, uncovered the problem of the MCP relay drivers triggering on noise. These evaluation tests were also valuable in establishing a redundancy checkout scheme for the MCP while it was installed in the spacecraft.

The second prototype was used as a prequalification test article for certifying both the MTE and the FTE before the official start of the qualification program. Sufficient time was not available for the breadboard- and prototype-development programs to provide useful information for the flight system design without a significant cost and schedule impact. Ideally, 6 months should be scheduled between the breadboard and first production item delivery dates for hardware as complex as the MCP.

Electromagnetic-Interference Considerations

While evaluating the first MCP prototype in the communications laboratory, the spacecraft contractor discovered that the GCC relay drivers were triggering on noise

voltages. At the beginning of the Apollo Program, one MCP unit was scheduled for environmental qualification tests and another unit for emi qualification tests. The emi test and success values were difficult to establish on a black-box level because the interference is an interrelated-systems problem. Therefore, the requirement for emi qualification tests on the black-box level was eliminated before the MCP qualification tests were scheduled. An overall emi test scheme was to be established on the spacecraft-test level.

Test Equipment Certification

The following schedule was achieved concerning certification of the FTE.

<u>Item</u>	<u>Date</u>
FTE test tape development start	October 28, 1965
MTE completion	November 14, 1965
FTE test tape completion	March 7, 1966
MTE recalibration	March 11, 1966
FTE test tape certification	April 6, 1966
FTE certification	April 8, 1966

Certification of the FTE was important in that this certification was a constraint to the start of the systems test portion of the MCP qualification program. The FTE certification, or development testing, could not begin without an MCP test article to process the responses to the test input signals. The MCP breadboard system, delivered in November 1965, was used in this development. This late delivery allowed only 6 months for development and certification testing of the FTE. This length of time was extremely short for testing, debugging, and certifying a test equipment system of this complexity. However, the original schedules allowed only a 2-month period from breadboard delivery to certification completion and qualification test start. This period was not sufficient to achieve the test equipment certification; therefore, the qualification start date was extended by 4 months.

The certification of the test equipment was achieved by using a production prototype MCP unit that was essentially identical to the qualification unit to be tested later. First, an acceptance test using manual test methods was performed on the prototype, and each redundant function was verified to be operating. This unit was then used as a test equipment certification unit, and the same test specifications were used. If every test function was processed through the certification unit and was recorded by the FTE with no anomalies, the test function was certified. If an anomaly occurred, then an analysis had to be performed to determine whether the test equipment or the certification unit had malfunctioned. This step-by-step method was demanding and time consuming, but the FTE was finally certified.

Production Delivery

The following schedule was achieved for the MCP production unit deliveries and modifications.

<u>Production delivery</u>	<u>Date</u>
Unit 1	January 14, 1966
Unit 2	March 30, 1966
Unit 3	April 5, 1966
Completion of design modifications to unit 1 after completion of contractor tests	May 1966
Unit 4	June 11, 1966
Modification of unit 3 to spacecraft 017 configuration	July 14, 1966
Unit 5	August 19, 1966
Unit 6	September 16, 1966
Modification of unit 4 to spacecraft 017 configuration	October 3, 1966

Of the six production units delivered, units 1, 3, and 4 required several design modifications to make them compatible with the MCP design configuration for spacecraft 017 and 020. The design changes were incorporated in production units 5 and 6 before delivery. The qualification unit 2 did not require modification because the design modifications did not require requalification testing. The MCP supported the spacecraft delivery and test schedule dates; however, some of the design changes and rework had to be accomplished during the idle vehicle test periods. For example, the rework was started after the MCP finished supporting the integrated systems test at the spacecraft contractor's facility and was completed before the next requirement to support tests in the vehicle at the NASA John F. Kennedy Space Center (KSC). Ideally, the spacecraft connectors would not have been disturbed, and the MCP would have been delivered to the KSC while installed in the spacecraft.

Qualification Tests

The following key schedule dates describe the qualification test program.

<u>Item</u>	<u>Date</u>
Original qualification test start	December 17, 1965
Actual qualification test start	February 17, 1966
MTE certification	March 11, 1966
Qualification production unit 2 delivery	March 30, 1966
Qualification production unit 3 delivery	April 5, 1966
FTE certification	April 8, 1966

<u>Item</u>	<u>Date</u>
Qualification test completion	April 23, 1966
Qualification report release	May 31, 1966

The original qualification test start date is listed to emphasize the importance of allowing adequate time to certify and evaluate test equipment. This original start date of December 17, 1965, was postponed 4 months for the GCC and SCC units because of previously mentioned problems with test equipment certification. The actual qualification program was able to be begun as early as February only because the qualification testing of the ADS unit was started before the GCC and SCC units. The FTE was not required for the postenvironmental tests of the ADS unit. The FTE was finally certified April 8, 1966, and was available for use during the MCP system-level functional tests for postenvironmental evaluations. These system tests of the MCP were programed on punched tape, and the test equipment automatically generated, switched, and routed the stimulus and response signals; measured the time of response; and evaluated the logic state of the circuitry being tested.

A detailed schedule of the qualification testing sequence is shown in figure 13. Items 1 to 15 in figure 13 represent keywords for coding the test activity during any specific test period. For example, from March 10 to March 15, during the qualification test of system 2, the activity was 15 (MTE functional tests). As the test results are discussed in the following paragraphs, the test sequence can be established by referring to figure 13.

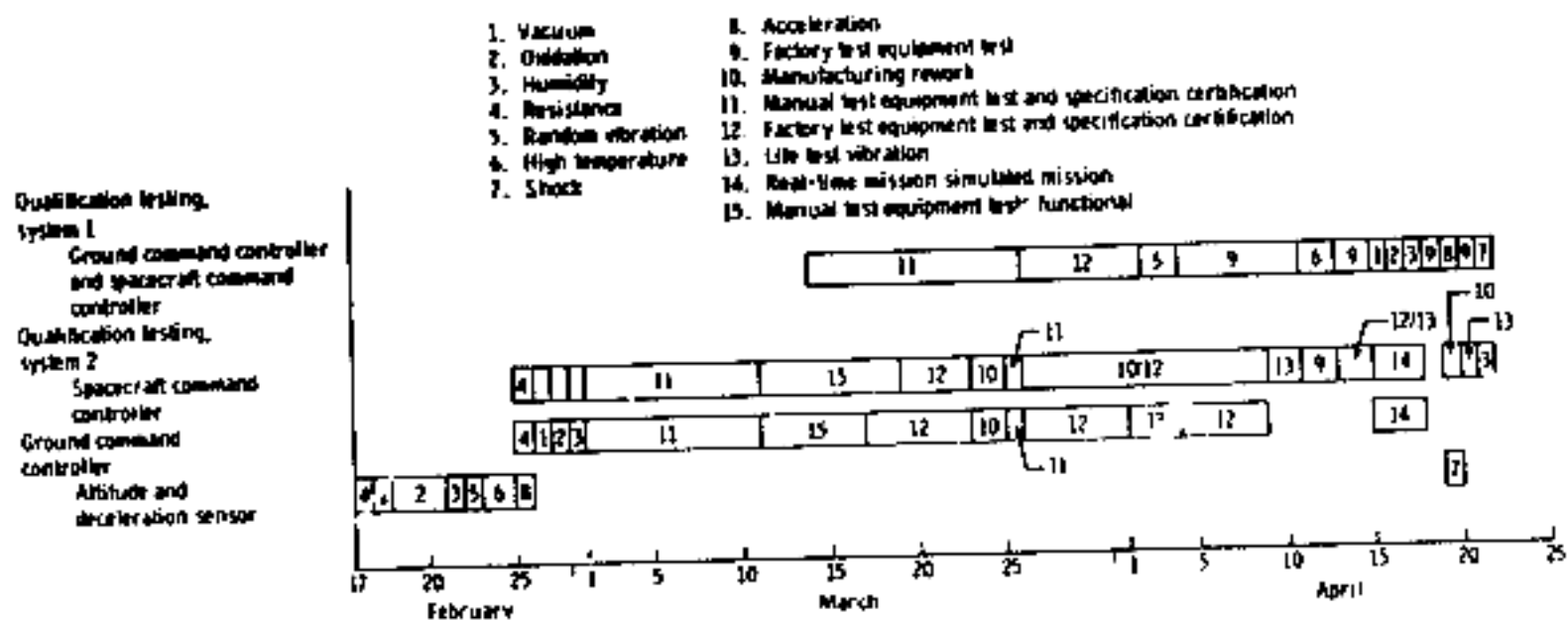

Figure 13. - Qualification testing sequence.

The ADS package of MCP production unit 2 was subjected to the qualification test environments. Because of the simple design of this sensor package, all the environmental tests, except shock, were completed in 1 week. Because this package also had

--	--	--	--	--	--	--	--

to support the life test, the shock environmental test was postponed until the end of qualification testing. The sensor package successfully completed the qualification tests with no anomalies, no visible physical damage, and no operational degradation.

The MCP production unit 2 (qualification test unit 2) was initially ready to begin qualification testing on February 26, 1966. However, the FTE either had not been completed or was not certified. Because of the critical schedule requirements, the qualification tests were started, using only a few manually initiated commands for each postenvironmental verification of the MCP. No failures were detected during the initial vacuum, oxidation, or humidity testing.

After the humidity test, the qualification test packages were to be given a complete package functional test, using the MTE. This equipment had been used earlier to complete the testing of qualification unit 2, but the new test specifications required box-level testing of redundant circuitry. These specifications had not been checked out against any package or with the MTE. When the postenvironmental (vacuum, oxidation, and humidity) testing was attempted, numerous problems were encountered and too many unknowns (such as MTE, test specifications, and MCP) were involved. As a result, the period between March 2 and April 2, 1966, was used to debug and certify the specifications and the MTE, to retest the MCP, and to check out the functional test tapes for the FTE. During this period, failures were detected in the packages; some failures were due to manufacturing errors not previously tested in the redundant circuits during sell-off; others were induced by the MTE. These failures reemphasized the critical requirement of entering a qualification test program with a good baseline; that is, with certified test equipment, verified procedures, and adequate specifications.

After qualification unit 2 finished serving as a test article for the certification of the automatic FTE, the test equipment was successfully used to complete a function test on qualification unit 2. The unit then entered the life test sequence on April 2, 1966. The purpose of this test was to verify that the MCP could perform normal mission functions after accumulating more than 500 hours of operating time. After the required number of operating hours was accrued, the MCP entered the real-time simulated mission run on April 15, 1966. The MCP proved to be capable of performing the function of a real-time mission after being subjected to random vibration levels and accruing more than 500 hours of operating time.

The MCP production unit 3 (qualification test unit 1) entered the vibration environment portion of the qualification test on April 2, 1966. The vibration effects to be investigated were the resonances of each package (resonance search) and the susceptibility of the MCP to random vibration. The postvibration physical inspection of the MCP indicated 35 instances of fractured solder joints on the pins of the SCC control assembly connector boards (fig. 14). The GCC had 10 loose or broken solder joints around similar pins. However, no functional test failures were attributed to the solder fractures around the pins. The corrective action for the cracked-solder-joint problem included soldering the terminals on both sides of the circuit strip (fig. 15) and adding a bracket to improve the wire-bundle routing. The corrective action was successful, and the problem did not recur during future vibration tests.

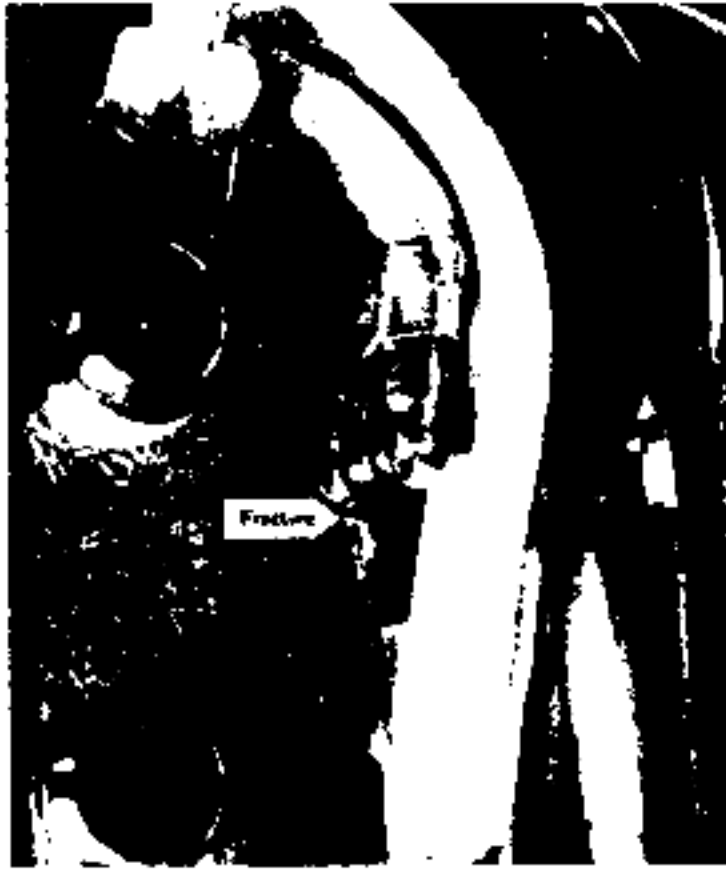

(a) Example 1.



(b) Example 2.



(c) Example 3.

Figure 14. - Fractured solder terminals.



(a) Orientation of rework area.



(b) Closeup of rework area.

Figure 15. - Repair method, soldering backside of terminal strip.

The second significant problem was detected during the humidity and posthumidity functional test portions of the qualification program. The reverse impedance of the MCP diode quads was below the specification limits after the 16-hour humidity test. These impedances were within the specified value (greater than 700 kilohms) after about 1 hour of drying. The diodes in the SCC were affected after being exposed to 95 ± 5 percent relative humidity; but, for normal unmanned flight, humidity was not expected to be a problem. The corrective action was to provide added protection by applying polyurethane (polycoat) to the control assemblies containing the diode quads (fig. 16). On April 22, 1966, after the polyurethane was applied to the control assemblies in qualification unit 2, the unit was retested in the humidity environment and satisfactorily met the specifications. The qualification tests were completed on April 23, 1966, and the test report was released on May 31, 1966.

Interface Verification Tests

The interface verification tests performed in the various engineering laboratories at the spacecraft contractor's facility provided much useful data. Some of the most significant results were as follows.

1. Identification of the relay driver emi problem in the GCC
2. Establishment of the concept of onboard redundancy tests for the MCP
3. Verification of the allowable SPS gimbal position mistrim parameters
4. Verification of the new design modifications before actual installation

5. Identification of the system interface incompatibilities
6. Provision of useful information for resolving spacecraft test anomalies

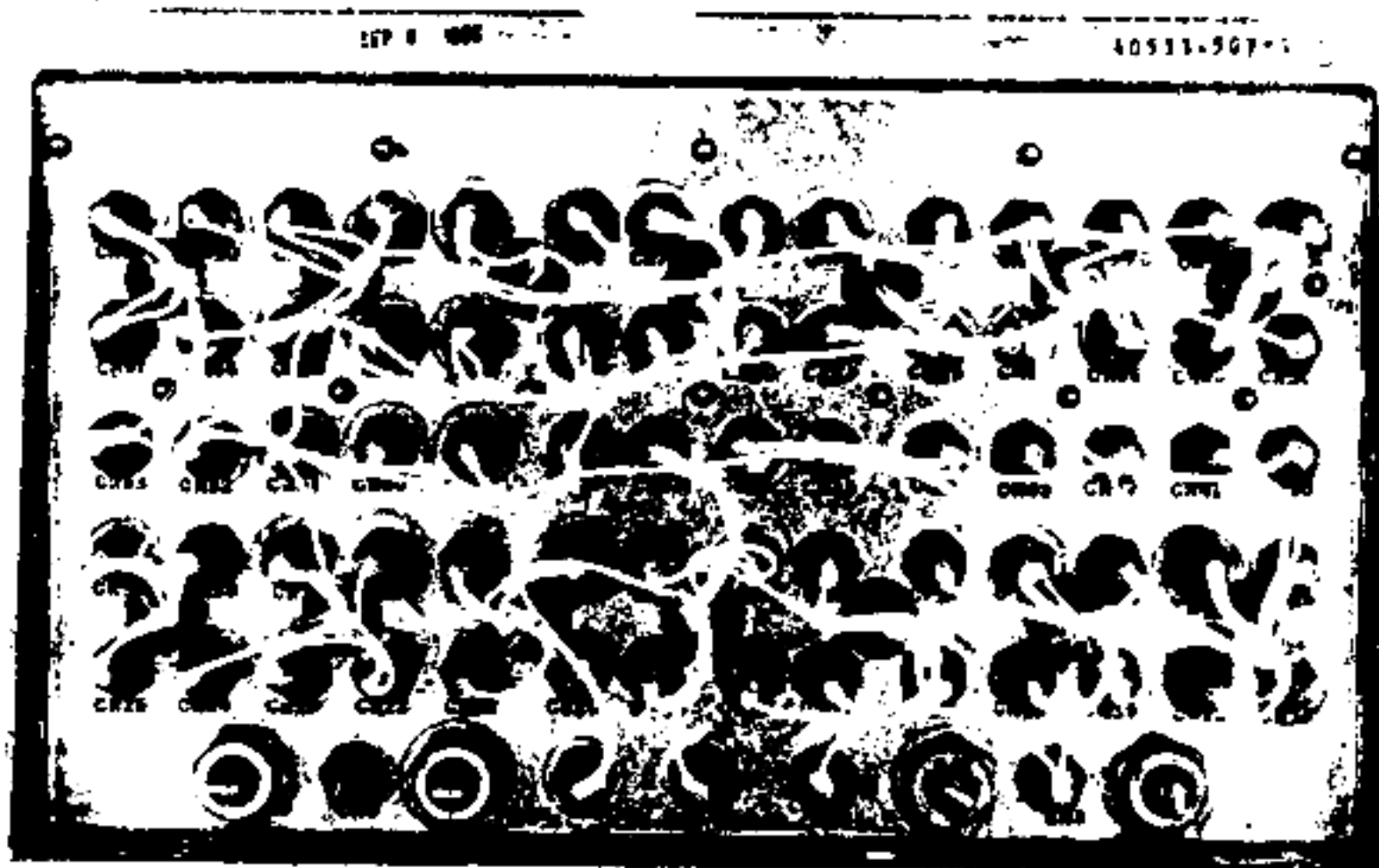

Figure 16. - Typical diode mounting bracket.

The MCP prototype unit 1 was delivered to the spacecraft contractor on December 3, 1965. This unit was first checked to verify electrical interface and compatibility with the spacecraft electrical power system. Unit 1 was then subjected to several different interface tests with individual spacecraft systems, such as the communications system and the MESC. Finally, the MCP prototype was tested, along with several other systems, in the guidance and control laboratory during the combined systems dynamic verification tests. The combined systems-test setup and the use of toggle switches to switch the internal grounds (G_1 , G_2 , and G_3) of the MCP suggested a method for testing redundancy of the MCP while in the spacecraft.

Spacecraft Tests

The MCP was installed in the spacecraft before the combined and integrated systems tests were started at the spacecraft contractor's facility. The MCP served as the interfacing unit between the G&N system and other input stimulus sources and the spacecraft flight systems that actually activated and performed the desired spacecraft output functions during the ground tests and also during flight. The MCP had no flight or spacecraft test measurement allocation, even though it had 10 connectors with over 500 measurement pins readily available for bench tests at the factory. The rationale for having no MCP flight measurements nor ground test measurements was that the unmanned vehicles would be instrumented and tested the same as the manned vehicles. Therefore, the functional operation of the MCP was determined by observing the functional operation of the related output systems that were instrumented. This rationale would have been adequate if the MCP processed programmer signals through single functional paths. However, the MCP contained numerous series-redundant and parallel-redundant paths (as previously described).

The Apollo Program had a requirement that each redundant path be verified as functioning properly just before launch. This requirement was interpreted to mean that the MCP, even though it was for unmanned flights, had to have its redundant paths verified in the spacecraft just before launch. The following schedule indicates the time required to implement the MCP redundancy tests.

<u>Event</u>	<u>Date</u>
NASA directed the contractor to accomplish spacecraft redundancy tests.	March 25, 1965
NASA management met with the contractor to resolve details concerning spacecraft redundancy checkout requirements.	April 1965
Contractor requested 78 automatic checkout equipment measurements for fault isolation of the MCP.	April 20, 1965
Measurement requirement request was denied.	October 1, 1965
NASA review determined that no plan was available for installed MCP redundancy test.	November 1965
MCP spacecraft redundancy test plan was initiated.	December 1965
Decision was made not to verify the MCP redundancy with acceptance checkout equipment.	February 3, 1966
The contractor processed an internal procedure to verify MCP redundancy.	April 21, 1966
An NASA management official directive emphasized requirement to perform MCP redundancy at the KSC for spacecraft 011, 017, and 020, and at the contractor's facility for spacecraft 017, and 020.	June 9, 1966
The first MCP redundancy test was performed at the KSC on spacecraft 011.	July 14, 1966

During the 1-year period between the original directive and the final processing of procedures for performing this test, the contractor maintained that the MCP redundancy tests would not be advantageous for the following reasons.

1. A 50-man-month effort in programing cost for acceptance checkout equipment could be saved.
2. A saving of 120 hours of spacecraft test time would result, compared with the 12 hours required for bench test equipment.
3. Interface equipment for the acceptance checkout equipment would have to be designed, fabricated, and certified.
4. The acceptance-checkout-equipment memory would be saturated.

Each reason had to be investigated and the problems resolved. Constant management pressure and insistence finally resulted in the performance of the MCP redundancy test for spacecraft 011 on July 14, 1968.

For the spacecraft 011 MCP redundancy test at the KSC, a special breakout box was designed to interface with the MCP ground-shorting connector. By using jumper wires on the breakout box, the test team could cycle the internal grounds (G_1 , G_2 , and G_3) of the MCP. Figure 12 shows the MCP/acceptance checkout equipment interface for the spacecraft 017 and 020 redundancy test; acceptance-checkout-equipment relays were furnished and automatically sequenced to cycle the grounds. The jumper wires that were opened and closed manually for spacecraft 011 served the same purpose as the acceptance-checkout-equipment relays but required more test time. The test actually consisted of three abbreviated mission-time-line test sequences with the required spacecraft systems powered up; the normal prelaunch countdown was performed but was stopped just before lift-off. One run through the abbreviated mission sequence of events was made with the appropriate opening and closing of internal ground G_1 . Two similar runs were then made with internal grounds G_2 and G_3 being cycled open and closed. These runs were to verify that the redundant paths of the MCP were operative while the unit was in the spacecraft. These redundancy tests were performed at the KSC for spacecraft 011, 017, and 020; also at the contractor's facility for spacecraft 017 and 020 just before the integrated test.

The redundancy tests revealed several malfunctions when the MCP was performing the function correctly, but a part of the redundancy capability was inoperative. During the spacecraft 011 test, two of the redundant time delays were inoperative. When these failures were detected, the spare MCP was installed and all the interfaces were reverified. (Refer to the section on time-delay failures for these failure analyses.)

HARDWARE PROBLEMS AND RESOLUTIONS

Reliability and Quality Objectives

In achieving the reliability established for the Apollo Program, a multitude of interwoven tasks was required.

1. Establishing a high-quality component qualification and screening program
2. Providing a lot traceability at the supplier and user levels for these qualified, high-reliability components
3. Establishing precise, uniform manufacturing techniques in a clean, controlled environment
4. Testing the assemblies at numerous points and stages of production
5. Qualifying the systems (after manufacturing completion) to the expected Apollo environments
6. Performing numerous system interface tests and simulation studies
7. Performing detailed spacecraft tests for each interface and mission phase
8. Analyzing and documenting each failure or anomaly that occurred during the program to determine the specific cause of the failure, to provide an acceptable corrective action, and to prevent future occurrence of the failure

Relay Failures

Each MCP system used approximately 1050 relays to establish redundant switching logic. These hermetically sealed, microminiature armature relays were developed in accordance with the product specifications and end-items specifications of the vendor and had a single qualified source of supply. The reliability objective in the relay procurement was the attainment of a life-failure-rate level of 0.08 percent in 10 000 relay operations with a 90-percent confidence level and a maintained life-expectancy confidence level of 60 percent per 100 000 operations at 303 K (85° F) under the specified rated loads. As shown in table VI, when a proper test and screening program is established, the majority of the relay failures occurs before installation of the system in the spacecraft. The last two columns of table VI are not exact because the same MCP unit was flown on both spacecraft 017 and spacecraft 020 and, because the MCP was not tested after the flight of spacecraft 020, relay failures could not be determined to have existed. Some of the relay failures at the system- and spacecraft-test level resulted from operator errors and were secondary-type failures caused by overcurrent applications or short circuits in the associated spacecraft wiring.

TABLE VI. - RELAY FAILURE HISTORY

Relays	Manufacturer tests			Vendor tests		Spacecraft contractor tests	KSC tests	Flight tests
	Screen	Life	Qualification	Production	Qualification			
Total failed	220	6	4	11	2	5	2	2
Total tested	10 000	300	300	6000	2000	3000	3000	3000
Failure, percent	2.2	2.0	1.3	.18	.1	.17	.07	.07

Solder Contamination in MCP Relays

The original end-item specification for hermetically sealed microminiature relays required that the evacuation and gas-filling hole in the relay case be sealed by using a fluxless solder process. The relay had to be cleaned ultrasonically, handled in a clean room, and inspected for contamination with a 10-power-minimum magnification unit during assembly and before sealing.

Two relays were found to be inoperative during the spacecraft O11 postflight analysis in September 1966. The subsequent failure analysis revealed solder-contamination particles that caused a short circuit in the relay case. The source of these solder particles was considered to be the soldering process to close the evacuation hole of the relay; actually, a steel plug was snapped into the hole, and it was sealed by soldering. The vendor terminated procurement of these solder-closeout relays on December 3, 1965. The new sealing process specified that the steel plug be snapped into the evacuation hole and a ring spotweld be used to seal the hole. This new process was considered to be contamination free. However, a total of 1843 of the relays procured before December 3, 1965, had already been used in the various MCP flight systems. The identification of the specific MCP systems containing the solder-closeout relays was obtained from the individual relay serial numbers and the lot traceability for high-reliability parts. System 1 for the MCP had 891 of the solder-closeout relays; system 2, 479; system 3, 195; system 4, 167; system 5, 81; and system 6, 30.

After the locations of all the solder-closeout relays had been determined, these relays were removed and replaced with welded-seal relays, but the task was not simple. One technique was to X-ray the relays in an attempt to determine whether the relays contained solder particles. However, the results were unsatisfactory because no conclusive correlation could be made between the analyses of the X-rays and the actual opening of the relay case and the physical inspection of the relay for contamination. The relay X-ray technique was officially eliminated December 15, 1966. The delay in delivery of such a large quantity of relays would result in an unrealistic schedule if each solder-closeout relay were to be replaced. On January 9, 1967, a rationale was established for exchanging the relays. Circuits dealing with spacecraft recovery were top priority, circuits dealing with mission success were second priority, and circuits having more than one solder-closeout relay in any redundant path were third priority.

The vendor began replacing the relays in accordance with this rationale to meet the spacecraft 017 scheduled delivery date of January 21, 1967. Control assemblies and plug-in printed circuit boards were exchanged among the MCP systems to ensure that correct relays were used in the MCP system for spacecraft 017. System 5 for the MCP was delivered to the KSC on January 11, 1967. The scheduled events for spacecraft 017 at the KSC were delayed so that the allowed schedule relief could be used to incorporate more improvements in the MCP. On February 9, 1967, the NASA and the spacecraft contractor reviewed the solder-closeout-relay situation, and a mission-event-by-event failure-effects analysis was used to arrive at a final determination for relay replacement. The actual replacement process was difficult because the printed circuit track of the control assemblies could be damaged while unsoldering the relay. The problem was finally corrected when all the solder-closeout relays in critical circuits had been replaced with welded-closeout relays.

Polarized Tantalum Capacitor Failures

During the spacecraft 011 postflight test, the MESC interface test, and the normal mission plugs-out test, a 3-second time delay in the MCP circuit (separation-abort command) to the MESC was timing out in approximately 4.7 seconds. During the failure investigation, the problem was isolated to a polarized tantalum capacitor in the filter circuit for the 28-V dc buses A and B. This 5-microfarad capacitor was used for filtering emi. Also, another filter capacitor in a different circuit was found to be failed. The emi filters were added to the MCP during the breadboard development testing to protect the time delays from bus-voltage spikes or transients of 4 microseconds or less duration. These transients could prevent the time delays from reinitializing and re-starting their time cycles. The time delays normally restart their time cycles after power has been removed and reapplied; therefore, a negative noise spike greater than 28 V dc would momentarily cancel the 28-V dc "on" signal to the time delay and would cause a recycle to zero. The instant the spike disappeared, the timer would begin timing again. For example, if a noise spike occurred at 1.7 seconds from $t = 0$ and was greater than -28 V dc, the spike would cause the 3-second time delay to restart, with the additional normal 3-second timeout totaling 4.7 seconds. The failure mode could also occur with the transient dropping the MCP voltage (e. g., to 5 volts, after the time delay had been on for 2.7 seconds). Because the capacitor in the resistance-capacitance timing circuit does not start charging from the zero-voltage point, the charging time constant would be less, and only 2 seconds instead of the normal 3 seconds would be required, resulting in a 4.7-second time delay. These examples only describe the failure modes and do not give the exact time the transient occurred. The corrective action added more capacitance to the emi filters in the MCP and was incorporated in the mission control programmer used for spacecraft 017 and 020.

Time-Delay Failures

For a 14-month period ending in April 1967, NASA and various aerospace industry representatives combined their efforts to resolve the MCP time-delay and fuse-diode failures. The failure mode was readily established shortly after the first time-delay circuit failed. Transistor Q_1 (fig. 17) of the time-delay circuit shorted (collector to base) causing zener diode CR_1 to overload, exceed the thermal rating, and fail, so that

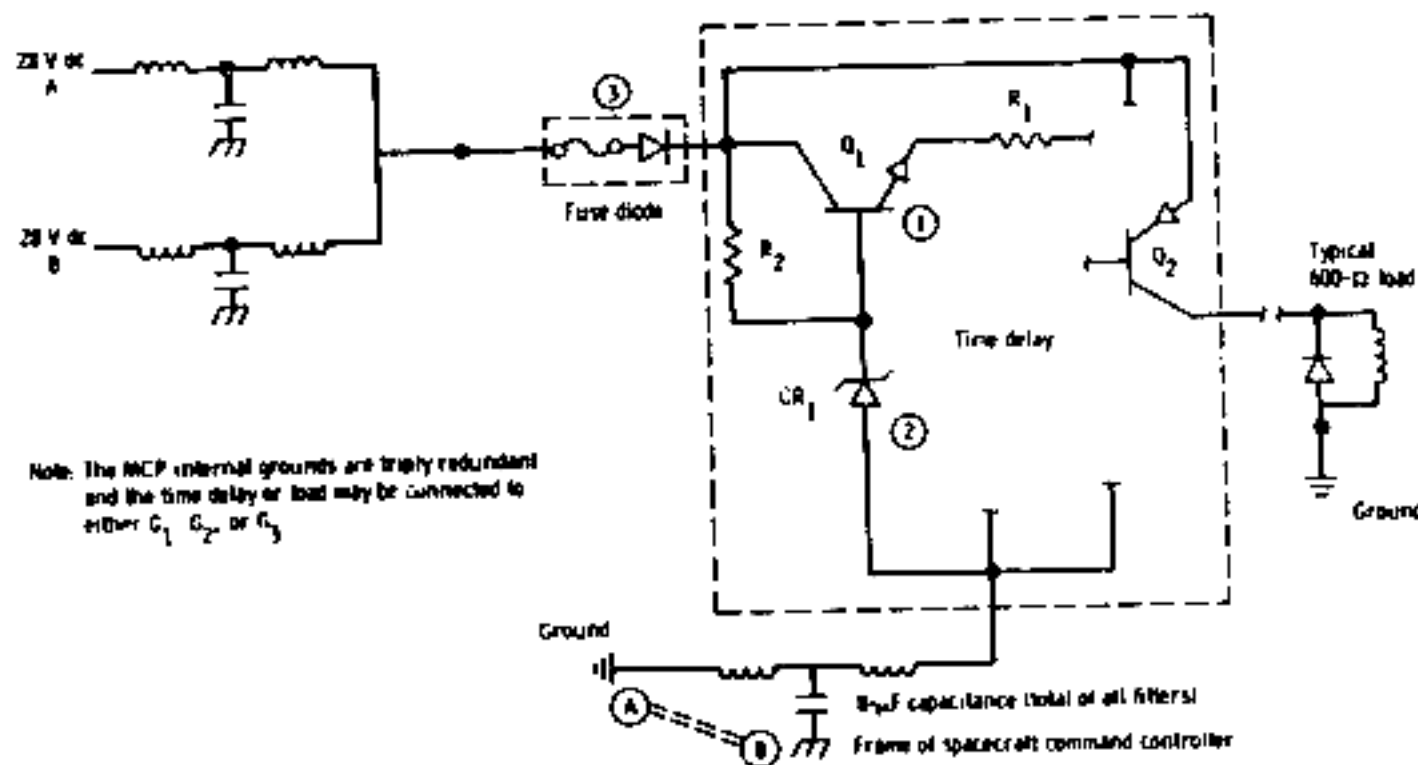

Figure 17. - Time-delay circuit schematic.

the fuse diode on the time-delay input was overloaded and failed (open circuit). Numerous attempts were made to establish the cause of the failure. The following list of significant events in the investigation indicates the amount of study on this problem.

1. In February 1966, the first 1-second time-delay failure occurred while the control assembly was being checked during manufacturing buildup and was then resolved as an operator error (overstress).
2. On March 6, 1966, the MCP was installed in spacecraft 011.
3. On March 22, 1966, an unassociated failure occurred in the SCC, and the unit was sent to the vendor for repair.
4. On March 24, 1966, the failures of two 3-second time-delay circuits in the same SCC was discovered during bench testing by the vendor before the repair and rework.
5. On April 2, 1966, the MCP repair was completed by the vendor, and the unit was reinstalled in spacecraft 011 to support testing. (At that time, no redundancy test of the MCP had been performed by the spacecraft contractor.)
6. On July 15, 1966, a 3-second time-delay circuit malfunctioned at the KSC during the integrated spacecraft test. (This occasion was the first that redundancy in the MCP had been verified in the spacecraft, but the time-delay circuit could have failed earlier.)
7. On July 18, 1966, SCC unit 1 was replaced with unit 4.

--	--	--	--	--	--	--	--

8. On August 10, 1966, during the flight readiness review, the representative for the vendor explained that each time-delay network was checked in the MCP by the bench test equipment before delivery, that a transient energy level of 250 V dc for 50 microseconds was required to break down the transistor, that the bench equipment had been instrumented to search for transients, and that 43 V dc was the highest transient determined. (The transistors are rated for 80 V dc.) Therefore, the representative concluded that the transient must be coming into the MCP from spacecraft wiring. This assumption was reasonable because inverter failures and other high-voltage spikes had previously been discussed at the flight readiness review. A recommendation was approved to put four 18-V dc zener diodes across the MCP input direct-current power buses in the spacecraft circuits external to the MCP.

9. On August 14, 1966, the zener diode network was approved for installation in spacecraft 011.

10. On September 8, 1966, the zener diode modification was installed and operational in spacecraft 017.

11. In September 1966, 8-, 3-, and 0.5-second time-delay circuits were found to have failed in SCC unit 5, which was supporting the spacecraft 017 tests. (These failures were found after the zener diode modification.)

12. In October 1966, the vendor continued to study the failures, attempted to correlate the high-reliability lot traceability, and analyzed the testing procedures. Two more time-delay failures were found in SCC unit 5.

13. On November 2, 1966, a special resistance check was devised to verify the operation of 3- and 0.2-second time-delay circuits at the KSC just before launch of spacecraft 017.

14. In November 1966, the vendor's test equipment was modified to incorporate the zener diode fix.

15. On December 12, 1966, a time-delay failure was found in SCC unit 6.

16. In December 1966, dual-redundant capacitors were added to the emi filters to solve the polarized tantalum capacitor-failure problem discussed previously. (During this investigation, the engineers discovered the large potential charge that these filter capacitors could store.)

17. In January 1967, two more time-delay failures were found in SCC unit 6, and a detailed extensive investigation was implemented.

18. In February 1967, the insulation-resistance megohm test used during acceptance testing was determined to be the cause of the failures. After the megohm test was eliminated and a multimeter was used to check the insulation resistance, no more time-delay failures occurred.

19. On April 6, 1967, the problem was officially closed.

The extensive engineering investigation to resolve the time-delay failures revealed that this failure, as well as several others, resulted from the transients caused by the 500-V dc megohm portion of the unit-level test at the vendor's facility. Failure of 8 diodes, 4 capacitors, 22 fuse diodes, and 14 time delays could be attributed directly to these transients. The listed failures were of an induced nature. During factory test, components were stressed beyond their capacity by an action of the test operator, who was not aware of the consequences. The action consisted of shorting an internal ground (G_1 , G_2 , or G_3) to the frame of the SCC after the megohm test. (Refer to points A to B in fig. 17.) This action was taken by the test operator to avoid electrical shock from filter capacitors that had been charged to several hundred volts when the megohm test voltage was applied to the frame of a control assembly in the SCC. The control assemblies were insulated from the frame, and this insulation was tested each time by the megohm test unit. The test specification required that 500 V dc be applied across a test point on the control assembly to the SCC frame for 2 minutes, then the insulation resistance would be read. During this 2-minute period, the filter capacitors were charged through the multitude of relay, time-delay, and differentiator paths.

The resistance-capacitance time constant was 48 seconds (6 megohms \times 8 microfarads = 48 seconds). Therefore, the filter capacitors would charge up to about 350 V dc in 1 minute and to greater than 400 V dc in 2 minutes. Voltage from the megohm test unit could be applied in either polarity. Test personnel reported that because no polarity requirement was stated in the specification, the test was performed without regard to polarity. As a result, the filter capacitors were charged either negative or positive with equal probability for any particular test.

Discussions with test personnel indicated that, instead of placing the megohm test probe on the control assembly test point, it was more convenient to touch a screw near the connector of the assembly. The screw was adjacent to exposed terminals that were part of the diode circuit. The probe could accidentally slip off the screw and contact the terminals. When this happened, the time constant for charging the filter capacitors was brief, and the capacitors charged up to slightly less than 500 V dc. To eliminate the possibility of electrical shock after completion of the insulation-resistance test, the test operator would usually short an internal ground terminal (G_1 , G_2 , or G_3) to the SCC frame, but sometimes the operator would short the metal plate of the control assembly to the frame. At the instant the short was applied, certain components in the command controller would be subjected to high electrical stresses. At times, this stress would exceed the breakdown strength of one or more components and subsequently resulted in a large transient current when the unshorted filter capacitors discharged.

Laboratory tests of transistor Q_1 , used in the time-delay circuits (fig. 17), were performed to determine the collector-to-base breakdown strength under pulse conditions. The test consisted of superimposing a positive pulse on a 28-V dc signal on the collector of transistor Q_1 in a time-delay circuit. The circuit was repeatedly pulsed, increasing amplitudes in 10-volt increments to 228 V dc (maximum pulse amplitude plus 28 V dc) or until failure, whichever occurred first. Fifty-six transistors were tested in the laboratory under these conditions, and 35 transistors failed. Each time a transistor failed, zener diode CR_1 was also overstressed and failed. The failed

transistor and zener diode had degraded or shorted junctions that were essentially the same as the failed parts in the SCC units of the MCP. During the laboratory test, the lowest pulse input to cause failure was at 108 V dc (28 V dc plus an 80-volt pulse). Six failures occurred at input signals of less than 150 V dc, 10 at less than 170, 20 at less than 198, and 35 at less than 228. Thirty of the transistors failed on the first voltage pulse at the failure level, five transistors failed by the fifth pulse. The 21 transistors that did not fail were ultimately pulsed 170 times at 228 V dc. After the cause of failure had been determined, it remained to be proved that the components that had not failed were not degraded by the megohm tests, even though they seemed to function satisfactorily. Three of the 21 transistors were selected at random and were pulsed for a minimum of 43 000 cycles without a failure. Therefore, the misapplication of the megohm test could cause immediate failures but would not cause the components to be degraded and susceptible to subsequent failure.

On the basis of the vendor's successful isolation of the cause of the failures, its proper corrective action to prevent future occurrences, and its demonstration that existing time-delay transistors in the MCP were not degraded, the problem was closed on April 6, 1967.

Cracking of Glass Seals Caused by Clipping of Relay Pins

The problem involving cracked glass seals did not adversely affect a program or a spacecraft, because the only two failures occurred in qualification unit 1 during the postflight test of spacecraft 011. The specification required that all component leads that mount on printed circuit boards shall not protrude through the board more than 0.76 millimeter (0.030 inch). The relays, diodes, transistors, and other electrical components using glass-to-metal seals around their leads (or pins) were discovered to be subject to a shock wave during the process of clipping the pin. This shock wave was transferred down the pin and could possibly crack the glass seals. (The wire cutters, diagonal-cutting pliers, or side-cutting pliers use a wedge or chisel effect to separate the wire.) At the instant of final metal separation, rather severe forces (or shock waves) were transferred along the wire.

The problem with the MCP relays was a result of the vendor's fabrication techniques, which required the leads to be clipped. The relays, including the pin seals, were first inspected and then inserted in the circuit boards; the leads were clipped, the cut pins were soldered, and the solder was inspected. (At this time, the relay-pin seals could not be seen.) The clipping operation mechanically stressed the relay pins and cracked some of the glass seals.

Whenever a glass seal cracked or the relay pin became loose in the glass seal, the pin was free to rotate; merely the wrist action of the technician clipping the pin could rotate the pin and alter the critical relay contact alignment (fig. 18). The manufacturing alignment procedures required that the contacts first be set at a minimum 0.127-millimeter (0.005 inch) clearance. An overtravel adjustment was then checked and established at 0.0635 millimeter (0.0025 inch) to effect the proper wiping action of the relay contacts and then the proper electrical transfer. Alignment of the contacts had to be within $\pm 3^\circ$. A projected viewgraph, which magnifies the contacts many times

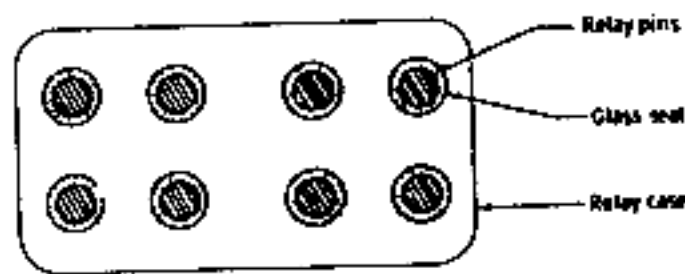

(a) Bottom view of relay-case header.

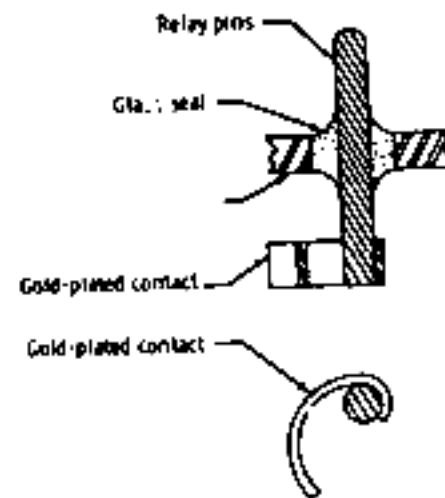

(c) Cross section of pin entering relay header and the glass seal.

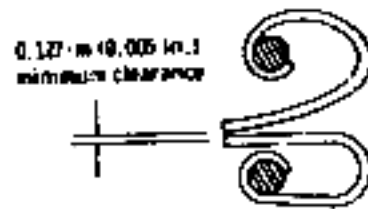

(b) Top view of relay pins with contacts in open configuration.

Figure 18. - Relay schematics to describe glass-seal problem.

their actual size, was used by the manufacturer to inspect and check these adjustments. Failure or improper action of the relays could occur for insufficient contact gaps or for contact gaps with too great a clearance. To prevent future problems, the vendor eliminated the relay clipping during the manufacturing process. An NASA Flight Safety Information Bulletin was published to notify all Apollo Program participants of the hazards of clipping terminals with glass-to-metal seals.

FLIGHT PERFORMANCE

The MCP served the three final unmanned Apollo flights without a flight anomaly caused by the system. The following discussion of the three spacecraft gives more details concerning the flight performance.

Mission AS-202

Apollo mission AS-202 (spacecraft 011), using an uprated Saturn I launch vehicle, was launched on February 26, 1966. The MCP consisted of SCC unit 4, GCC unit 1, and ADS unit 1. The MCP system configuration production unit numbers are given to emphasize that SCC unit 4 was refurbished to serve as a spare for spacecraft 017 and 020. The contractor was officially notified on October 12, 1966, to perform this refurbishment. The MCP was the first Apollo system to be considered for reuse in flight.

--	--	--	--	--	--	--	--

The postlaunch report for mission AS-202 stated that the MCP "automated the sequential event controls that would be normally operated by the flight crew." The report also stated that these sequential event controls, which included the MCP, "functioned satisfactorily throughout the flight, and the related test objectives were met." The only problem mentioned was a data-sampling-rate problem. Measurements CE0321X and CE0322X (parachute disconnect at landing) were not received by telemetry. The MCP disconnected the parachutes after landing but turned off the logic bus power 35 to 40 milliseconds after the parachutes were disconnected. This sequence was normal but it did not allow sufficient time for the telemetry, which had a sampling rate of 10 samples per second (100 milliseconds between samples), to receive the signal before the bus power was removed.

Apollo 4 Mission

The Apollo 4 mission (spacecraft 017) was launched on November 9, 1967. Apollo 4 was the first mission to use a Saturn V launch vehicle. The Apollo 4 Mission Report stated that "sequencing of the mission control programer was satisfactory throughout the mission." The mission report continued as follows: "The mission control programer was primarily a passive device, and no specific instrumentation was included for its analysis. Verification of continuity at the proper time was the only criterion considered during evaluation of this programer. Proper performance was indicated throughout the mission." The report could have included a statement that the MCP was used for unmanned missions only and that the flight downdata link could not provide measurements for the unmanned system; therefore, other interfacing system measurements were evaluated to determine the MCP performance.

The postflight tests of the MCP, as stated in the mission report, evaluated the MCP redundancy and verified that the programer had functioned properly. A more detailed and complete inspection of the MCP was performed by the manufacturer during the process of refurbishing the MCP for use as a spare for spacecraft 020. This refurbishment was successfully accomplished because the same MCP flown on spacecraft 017 was subsequently flown on spacecraft 020.

Apollo 6 Mission

The Apollo 6 mission (spacecraft 020) was launched on April 4, 1968. Apollo 6 was the second mission to use a Saturn V launch vehicle and was the last unmanned Apollo mission. The Apollo 6 Mission Report stated that "sequencing of the mission control programer was satisfactory throughout the mission." A brief mention was made concerning the stable I and stable II flotation attitudes. "The Apollo 6 mission was the first mission in which the command module assumed the stable II (inverted) flotation attitude after landing." The ADS unit of the MCP correctly sensed this attitude and initiated the sequence that uprighted the spacecraft.

The mission report continued: "The mission control programer supplied control function inputs to various systems during the flight. No specific instrumentation was designed to analyze programer performance; however, verification of continuity at the proper time showed proper programer performance throughout the mission." This

statement is true of all the MCP flight evaluations. No measurement points were available to determine the MCP outputs directly. The sequencing and performance of the interfacing systems that were instrumented could be evaluated and thereby allow an indirect determination of the MCP performance.

The Apollo 6 report also stated that "the same programmer (except for the altitude and deceleration sensors) was used on the Apollo 4 and Apollo 6 missions." This MCP had been refurbished to serve as a spare for spacecraft 020, and a test anomaly at the KSC resulted in the spare MCP (which was previously flown on Apollo 4) being installed in spacecraft 020. The NASA management decided to reuse this MCP after a thorough analysis at the flight readiness review.

CONCLUDING REMARKS AND RECOMMENDATIONS

Unmanned Flight Planning

The requirements for unmanned flights should be established early in the mission planning to prevent changes from affecting the hardware design. The design of the unmanned sequencing units should be as flexible as possible with the realization that, in dynamic programs for space flights, several mission changes are inevitable.

The items and sequences that are subject to change during unmanned flights (such as tape recorder sequencing, camera sequencing, gimbal actuator motor "off" and "on" times, and developmental instrumentation sequencing) should be placed in a software program or in some erasable memory device so that the items could be readily changed without affecting the hardware design.

Development Schedule

The development of the mission control programmer was delayed by the NASA up to 2 years compared to other electrical subsystem developments; the programmer was started in 1964 while other subsystems were started in 1962. In future space-flight programs, the unmanned test flight hardware should be planned and scheduled with priorities similar to those of the operation hardware to allow sufficient time for hardware test and evaluation.

A minimum of 6 months should be allowed in the development schedule between breadboard system delivery and production system delivery for hardware as complex as the mission control programmer. Doing so would allow a proper evaluation of the breadboard with the test results being returned to hardware design before the hardware is produced. The required hardware changes could then be made on a lower cost basis.

Test and Test Equipment

The 6-month certification period required for the automated factory test equipment designed for the mission control programmer was not excessive. The design for test equipment that is to be used for small total quantities of deliverable systems should

be, as far as possible, relatively simple, flexible, and general purpose. Engineering man-hours could have been better expended in actually testing the hardware manually (for each of the six programmer systems delivered) rather than in preparing automated equipment to run the actual acceptance test in less time. The test equipment flexibility should be such that it can be easily reconfigured and recertified for the numerous, expected flight-hardware modifications.

The unmanned flight hardware should be designed to conform to the same spacecraft test procedures that are used for the operational hardware. For example, if the spacecraft method of verifying operational redundancy was removal of power to system A to verify system B and vice versa, the unmanned equipment design should be compatible with the planned operational test methods.

During the mission control programmer time-delay-failure investigation, experience indicated that the detailed test procedures at all levels of systems test must be followed exactly by each operator. Even slight variations from the established procedures can cause many unsuspected problems.

Hardware Problems

The mission control programmer relay failures can generally be attributed to an early method of solder sealing the evacuation and gas-filling hole. The solder sealing process would sometimes result in solder particles inside the relay case; the particles floated across the contacts in the zero-g environment. A new sealing process was developed in which a steel plug was snapped into the relay evacuation hole, and a ring spotweld sealed the plug to the case. The new welding method ended the solder-contamination problem. It is recommended that solder-sealed relays not be used on future space flights.

Experience indicated the ineffectiveness of using X-ray techniques to identify relays that had solder particles in the sealed cases. Without opening the sealed cases, no correlation could be achieved between cases actually not containing solder particles and those that the X-ray techniques indicated as not containing the particles.

The time-delay failures resulted in the most extensive failure analysis and investigation activity that occurred during the mission control programmer development. One area that was misleading during the failure analysis was that each time delay was verified "good" during the programmer contractor's acceptance test just before delivery from the factory to the spacecraft; then, after the programmer was installed in the vehicle for the test support/interface verification activity, one to three time delays indicated "failed" during the first spacecraft test of programmer redundancy. The failure mode was finally determined to be that the time-delay transistors failed "open circuit" by the sudden discharge of a 500-volt potential that had been stored in the filter capacitors during the megohm insulation test at acceptance. Only after much investigation was it determined that the test operator shorted the filter capacitor to ground (not a normal documented test procedure) just before delivery of the programmer from the acceptance test area. The discharge current followed several sneak paths and would burn out one or more of the time-delay transistors. The corrective action was to stop the megohm insulation test as part of acceptance. Future programs should ensure that test operators

--	--	--	--	--	--	--	--

be cautioned to follow the test procedures exactly and not add any unique procedure such as manually discharging capacitor charge buildups as the unit is removed from the teststand. After the 500-volt insulation check was eliminated, no transistor failures occurred. Future electronic test designers should be especially aware that large filter capacitors can store voltages of a sufficient level to damage low-voltage-level devices.

Lyndon B. Johnson Space Center
National Aeronautics and Space Administration
Houston, Texas, January 22, 1975
953-36-00-00-72

National Aeronautics and
Space Administration

Lyndon B. Johnson Space Center
2101 NASA Road 1
Houston, Texas 77058-3696



Reply to Action:

AP4-FOIA-98-212

June 29, 1998

Mr. John Greenwald, Jr.

Dear Mr. Greenwald:

This is in response to your Freedom of Information Act (FOIA) request, dated June 21, 1998, and received June 22, 1998, for a copy of the Apollo experience report: "Guidance and Control Systems: Mission Control Programmer for Unmanned Missions AS-202, Apollo 4, and Apollo 6", NASA-TN-D-7992, Jul 01, 1975, JSC.

The requested information is enclosed.

Per NASA Regulations [14 CFR Sec. 1206.700 (I)(2)], the fee for the enclosed information is waived as the cost is less than \$5.

Sincerely,

A handwritten signature in cursive script, appearing to read "Stella Luna".

Stella Luna
FOIA Coordinator
Community Affairs Branch
Office of Public Affairs

Enclosures