

THIS FILE IS MADE AVAILABLE THROUGH THE DECLASSIFICATION EFFORTS AND RESEARCH OF:

THE BLACK VAULT

THE BLACK VAULT IS THE LARGEST ONLINE FREEDOM OF INFORMATION ACT / GOVERNMENT RECORD CLEARING HOUSE IN THE WORLD. THE RESEARCH EFFORTS HERE ARE RESPONSIBLE FOR THE DECLASSIFICATION OF THOUSANDS OF DOCUMENTS THROUGHOUT THE U.S. GOVERNMENT, AND ALL CAN BE DOWNLOADED BY VISITING:

[HTTP://WWW.BLACKVAULT.COM](http://www.blackvault.com)

YOU ARE ENCOURAGED TO FORWARD THIS DOCUMENT TO YOUR FRIENDS, BUT PLEASE KEEP THIS IDENTIFYING IMAGE AT THE TOP OF THE .PDF SO OTHERS CAN DOWNLOAD MORE!

National Aeronautics and
Space Administration

George C. Marshall Space Flight Center
Marshall Space Flight Center, AL 35812



Reply to Address:

CO50

JUL 07 1998

Mr. John Greenwald, Jr.
[REDACTED]

Dear Mr. Greenwald:

This responds to your Freedom of Information Act request (denominated for our records as FOIA #98-163) for a copy of the Entry Vehicle Control, NASA SP-8028. Please find enclosed one copy of the requested document.

Search, review and reproduction costs, as published at 14 CFR 1206.700, are eighteen dollars and ten cents (\$18.10; 46 pages @\$.10 and \$13.50 - search and review time). Your check should be made payable to the "National Aeronautics and Space Administration" and forwarded to the Collection Agent, George C. Marshall Space Flight Center, Code BF20, Marshall Space Flight Center, AL 35812. Interest may be charged from the 31st day after the date of this letter if assessed fees are not paid.

Sincerely,

A handwritten signature in cursive script that reads "Judi A. Hollingsworth".

Judi A. Hollingsworth
FOIA Manager

Enclosure

NASA
SPACE VEHICLE
DESIGN CRITERIA
(GUIDANCE AND CONTROL)

NASA SP-802B

ENTRY VEHICLE CONTROL



FACILITY FORM 602

<u> N70-28538 </u> (ACCESSION NUMBER)	<u> </u> (THRU)
<u> 51 </u> (PAGES)	<u> 1 </u> (CODE)
<u> ✓ </u> (NASA CR OR TMX OR AD NUMBER)	<u> 21 </u> (CATEGORY)

NOVEMBER 1969

NATIONAL AERONAUTICS AND SPACE ADMINISTRATION

FOREWORD

NASA experience has indicated a need for uniform criteria for the design of space vehicles. Accordingly, criteria are being developed in the following areas of technology:

Environment
Structures
Guidance and Control
Chemical Propulsion

Individual components of this work will be issued as separate monographs as soon as they are completed. This document, "Entry Vehicle Control," is one such monograph. A list of all previously issued monographs in this series can be found on the last page of this document.

These monographs are to be regarded as guides to design and not as NASA requirements, except as may be specified in formal project specifications. It is expected, however, that the criteria sections of these documents, revised as experience may indicate to be desirable, eventually will become uniformly applied to the design of NASA space vehicles.

This monograph was prepared under the cognizance of the NASA Electronics Research Center. Principal contributors were J. Zvara of Kaman AviDyne and Prof. A. E. Bryson of Stanford University.

The effort was guided by an ad hoc advisory panel chaired by Professor Bryson. The following members participated in advisory panel activities:

E. J. Adkins	NASA, Flight Research Center
R. Bohling	NASA, Office of Advanced Research and Technology
F. J. Carroll	NASA, Electronics Research Center
T. Chambers	NASA, Manned Spacecraft Center
D. DeBra	Stanford University
W. Geissler	McDonnell Douglas Corp.
C. Janow	NASA, Office of Advanced Research and Technology
C. Moosbrugger	Honeywell, Inc.
S. Osder	Sperry Rand Corp.
K. Sandoval	Aerospace Corp.
R. Roberson	University of California

The assistance of other scientists and engineers who contributed to this monograph is appreciated. Comments concerning the technical content of these monographs will be

welcomed by the National Aeronautics and Space Administration, Office of Advanced Research and Technology (Code RVA), Washington, D.C. 20546.

November 1969

CONTENTS

	Page
1. INTRODUCTION	1
2. STATE OF THE ART	2
2.1 Mercury Entry Control	2
2.1.1 System Description and Operation	2
2.1.2 Flight Experience	5
2.2 Gemini Entry Control	6
2.2.1 System Description and Operation	6
2.2.2 Flight Experience	9
2.3 Apollo Entry Control	9
2.3.1 System Description	11
2.3.2 System Operation	14
2.3.3 Flight Experience	16
2.4 X-15 Entry Control	17
2.4.1 System Description	17
2.4.2 Development and Flight Experience	22
2.5 ASSET Entry Control	26
2.6 PRIME Entry Control	27
2.7 Future Trends and Summary	27
3. CRITERIA	29
3.1 Performance	29
3.2 Crew Safety and Flightworthiness	30
3.3 Additional Considerations	31
4. RECOMMENDED PRACTICES	31
4.1 Statement of the Problem	31

4.2 Performance 33

 4.2.1 Performance Analysis 33

 4.2.2 Simulation Studies 34

 4.2.3 Tests 35

4.3 Crew Safety and Mission Success 36

REFERENCES 39

NASA Space Vehicle Design Criteria Monographs Issued to Date 45

Entry Vehicle Control

1. INTRODUCTION

Almost every spacecraft requires an active attitude stabilization and control system during atmospheric entry to steer the vehicle in accordance with the guidance commands, to prevent undesired vehicle oscillations, to align the vehicle for terminal landing, and to steer the vehicle along a flightpath where aerodynamic heating and load limitations will not be exceeded.

Factors that influence the design of the entry-control system include

- (1) Vehicle mass and geometric characteristics
- (2) Vehicle aerodynamic characteristics
- (3) Vehicle aerodynamic-heating characteristics, and nature of the heat shield
- (4) Payload and crew physical limitations
- (5) Initial atmospheric entry conditions
- (6) Type of moment-generation devices available
- (7) Vehicle sensing and control equipment
- (8) Attitude accuracy and speed-of-response requirements
- (9) Crew safety and mission success requirements
- (10) Guidance-system and flightpath constraints

Improper design or operation of the entry-control system can cause excessive attitude-control propellant consumption or large landing-position errors, or cause the entry vehicle to experience oscillatory motions that in extreme cases can cause loss of the vehicle or failure of the terminal-landing device.

The entry-control system should make effective use of sensing, data processing, display, and control equipment required for other mission phases, so that a minimum of additional equipment and expendables is required for entry control. It should be as insensitive as possible to variations in vehicle parameters, atmospheric conditions, and initial entry conditions. It should make effective use of the crew's capability for monitoring, backup, or manual control during entry.

This monograph is applicable to all types of entry vehicles that use aerodynamic forces for deceleration. The entry phase of flight is assumed to begin with the orientation of the vehicle for entry into the atmosphere and to end at 100 000 ft altitude or deployment of the terminal-landing device.

The entry-control system is concerned with the vehicle attitude motions about the center of mass. It is closely coupled with the entry-guidance system, which is concerned with the motion of the vehicle center of mass along a desired flightpath. The guidance problem for entry vehicles is covered in NASA SP-8015.

2. STATE OF THE ART

The state of the art of entry control is derived primarily from design, development, and flight experience with the Mercury, Gemini, Apollo, X-15, ASSET, and PRIME vehicles, and from preliminary design studies of advanced logistics vehicles. The entry-control systems of these vehicles are briefly described and appraised.

2.1 Mercury Entry Control

Design of the Mercury entry-control system was strongly influenced by stringent requirements for crew safety; the necessity to minimize power consumption and weight; the desire for simple, highly reliable redundant modes; and an absolute requirement that the pilot have the capability of controlling spacecraft attitude. Information on the system presented in references 1 to 6 is summarized below.

2.1.1 System Description and Operation

The Mercury entry vehicle was a nonlifting body that followed a ballistic trajectory in the atmosphere. Thus, no changes in the entry flightpath were possible after retrofire. The entry-control system was first used to establish and maintain the proper entry attitude (1.5 deg nose down). When the deceleration reached 0.05 g, an entry mode was initiated in which pitch and yaw damping were provided to insure that oscillations would not exceed ± 4 deg/sec until deployment of the drogue chute. A steady roll rate of 10 to 12 deg/sec was maintained to minimize landing-point dispersions and equalize aerodynamic heating on the structure.

There were four control systems on the vehicle that could be used singly or in various combinations: a fully automatic control as provided by the automatic stabilization and control system (ASCS), a completely manual proportional control (MP), and combinations of automatic and manual control as provided by the rate stabilization and control system (RSCS) or the fly-by-wire (FBW) type of manual control. All but the ASCS mode were

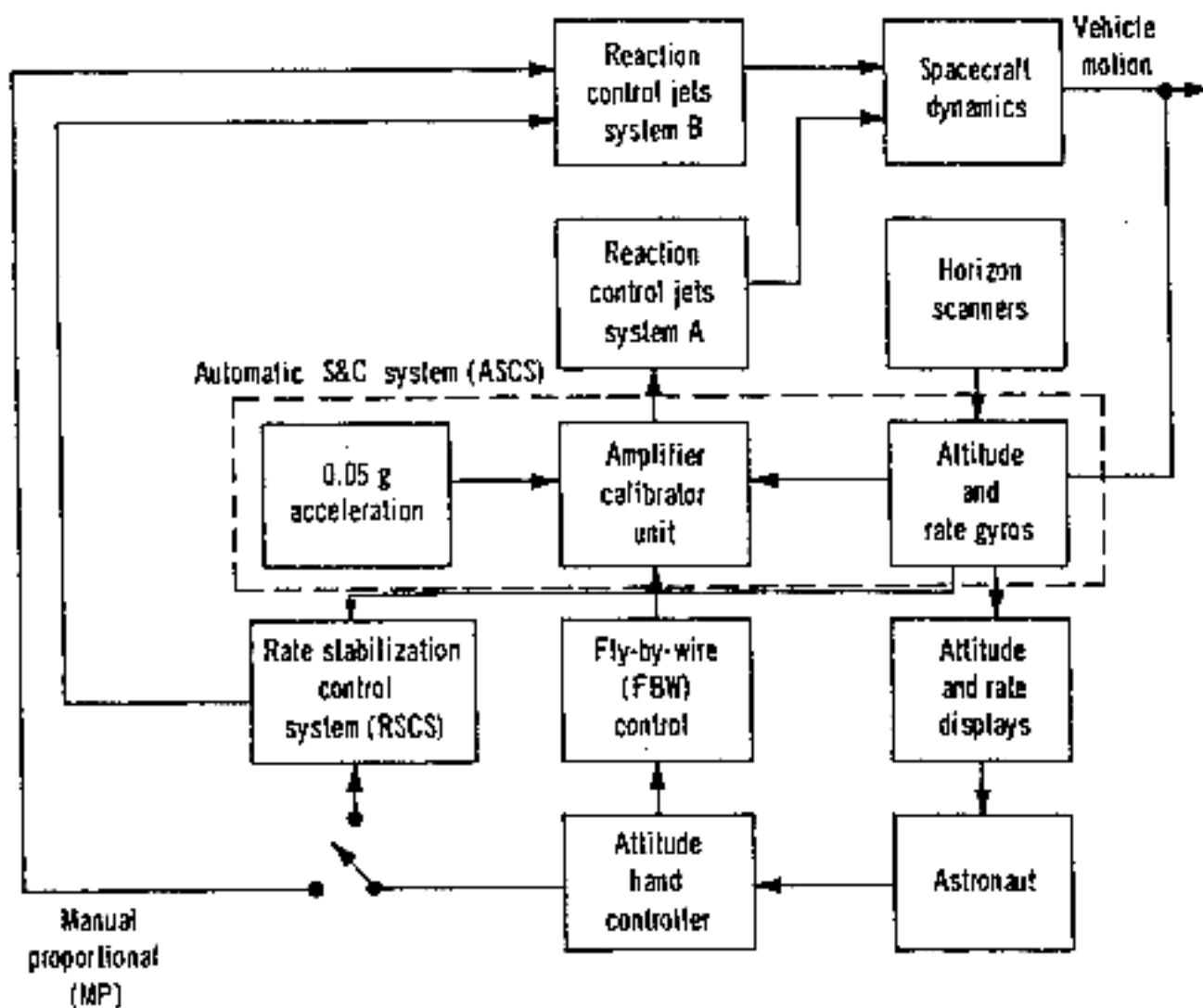

Figure 1.—Mercury control-system functional diagram.

controlled by pilot actuation of the three-axis hand controller. A functional diagram of the control system is shown in figure 1.

The two reaction-jet systems (A and B) were completely independent, with separate hydrogen peroxide fuel tanks, separate fuel-flow control valves, and separate sets of jet thrusters. The jet-thruster configurations are shown in figure 2 and table I. The ASCS and FBW arrangements were used to control the thrusters in system A, and the MP and RSCS modes controlled system B jets. Metered quantities of hydrogen peroxide were decomposed in silver-plated catalyst beds in each thruster to provide the desired impulse.

In the MP system, mechanical linkages transmitted the hand-controller movements to proportional-control valves, which regulated the flow of fuel to the thrusters. This system required no electrical power. The RSCS used a combination of hand-controller positions and

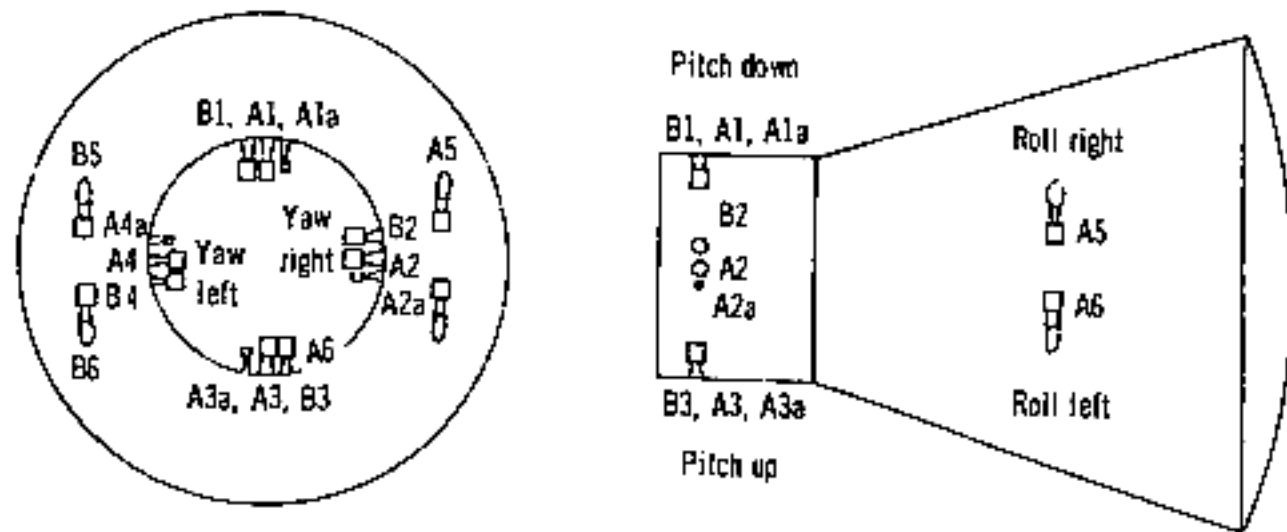

Figure 2.—Mercury entry-control jet configuration.

Table I.—Mercury Entry Control Jet Configuration

Attitude command	Reaction jet system A		Reaction jet system B	
	Jet	Thrust (lb)	Jet	Thrust (lb)
Pitch up	A3/A3a	24/1	B3	0-24
Pitch down	A1/A1a	24/1	B1	0-24
Yaw right	A2/A2a	24/1	B2	0-24
Yaw left	A4/A4a	24/1	B4	0-24
Roll right	A5	6/1	B6	0-6
Roll left	A6	6/1	B5	0-6

the computing components of the automatic system to provide rate control. The FBW system was operated by movement of the hand controller to operate the solenoid control valves electrically. Certain control modes could be operated simultaneously, such as the ASCS and MP, or FBW and MP, to provide complete control even with certain malfunctions in each mode.

The ASCS included a two-degree-of-freedom directional gyro; a two-degree-of-freedom vertical gyro; pitch-, yaw-, and roll-rate gyros; an amplifier-calibrator unit; and a 0.05 g accelerometer switch. The outputs of the attitude and rate gyros were transmitted to the roll, pitch, and yaw switching logic, which activated appropriate reaction-control thrusters to maintain the desired attitude and rates. Infrared-sensing horizon scanners provided attitude signals in roll and pitch to align the attitude gyros.

The RSCS provided rate damping in case of ASCS failure. Control-stick motion was transmitted to the rate damper by means of potentiometers attached to the stick. Spacecraft angular rates were made to follow stick displacement up to a maximum of 12 deg/sec for all axes.

The astronaut could, at any time in the mission, switch off the ASCS or RSCS and control the capsule manually by the MP or the FBW systems. The proportional valves in the MP system were designed to provide a linear relation between hand-controller deflection and thrust. The astronaut, when exercising manual control, monitored attitude and attitude rate on indicators mounted on the control panel. The FBW included provision for high or low impulse from the thrusters. This provision allowed the astronaut to conserve fuel by using the low-thrust position when small corrections were required.

2.1.2 Flight Experience

Control-system failures of one type or another were experienced on all but one of the six manned Mercury flights. These failures were overcome because of the redundancy designed into the system and the ability of the pilot to exercise attitude control manually. The problems encountered are enumerated below without detailed comment. Further information may be found in reference 5.

The single most prevalent malfunction in the control system during the early manned-flight program was the intermittent failure of the small 1-lb thrusters. This failure caused early termination of the MA-5 chimpanzee flight. In addition, during a manned suborbital flight (MR-3) a 6-lb thruster also failed to produce thrust when required. Redesign of the thrust-chamber assemblies (ref. 5) eliminated this problem on later flights. Horizon-scanner measurement errors occurred because of "cold cloud" effects, and on one mission, MA-7, a scanner circuit failure required the astronaut to establish spacecraft attitude for retrofire. Modifications described in reference 5 eliminated these problems. Although the control system performed satisfactorily during the MA-9 mission, an electrical short circuit that occurred at two of the power-carrying plugs of the ASCS made it necessary to use manual control during entry. An open circuit in the pitch-rate gyro input to the amplifier-calibrator of the ASCS caused the MA-4 spacecraft attitude to be in error at retrofire, which in turn resulted in a 75 n. mi. landing error.

2.2 Gemini Entry Control

The Gemini entry-control system design was based on experience gained from Mercury; it was a more flexible system, which emphasized the pilot's control ability. Flight safety was achieved by relying on simpler redundant systems. Information on the entry-control system presented in references 7 to 17 is summarized in the following section.

2.2.1 System Description and Operation

One of the objectives of the Gemini program was the development of active entry flightpath control to reach a precise landing point. The vehicle was axially symmetrical, with its center of mass offset from the centerline as shown in figure 3. It trimmed at an angle of attack that resulted in an average lift-drag ratio (L/D) of about 0.19. Trajectory control was accomplished by rolling the vehicle to the right or left in response to guidance-system or pilot commands. Zero lift was obtained (on the average) by continuously rolling the vehicle. Negative lift was not used.

A functional block diagram of the Gemini guidance and control (G&C) system is shown in figure 4. The control portion of the system includes the attitude-control and maneuver electronics (ACME), entry-control jets, attitude hand controller, and attitude display group. The ACME included two rate-gyro packages, each containing three orthogonally mounted rate gyros.

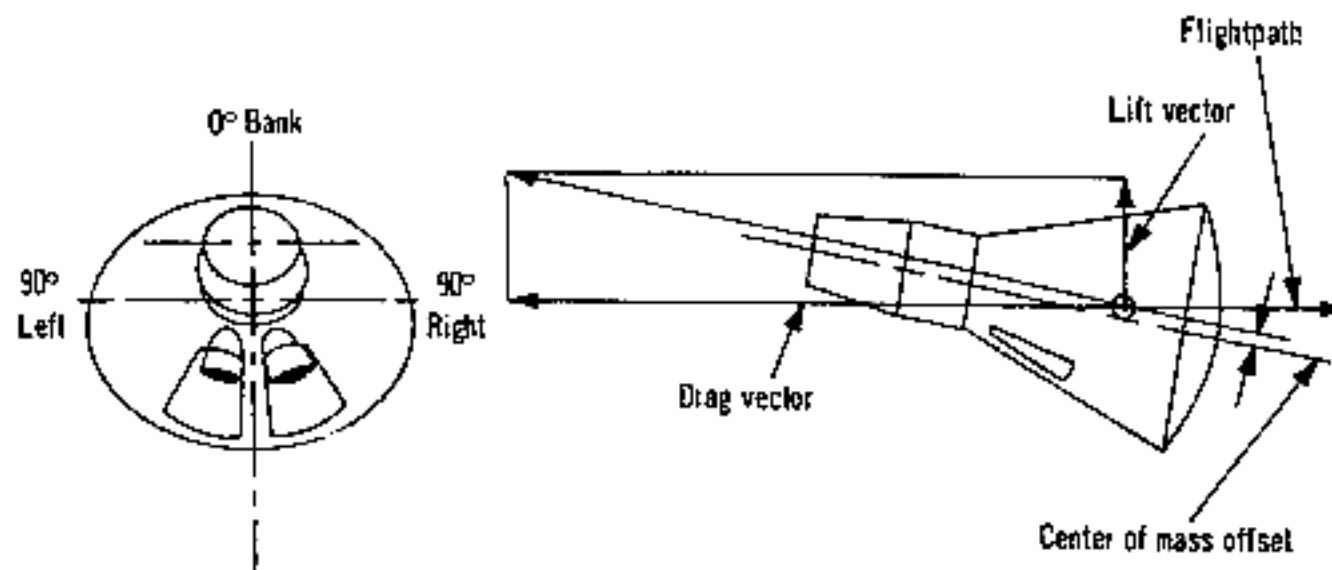

Figure 3.—Gemini vehicle trim condition.

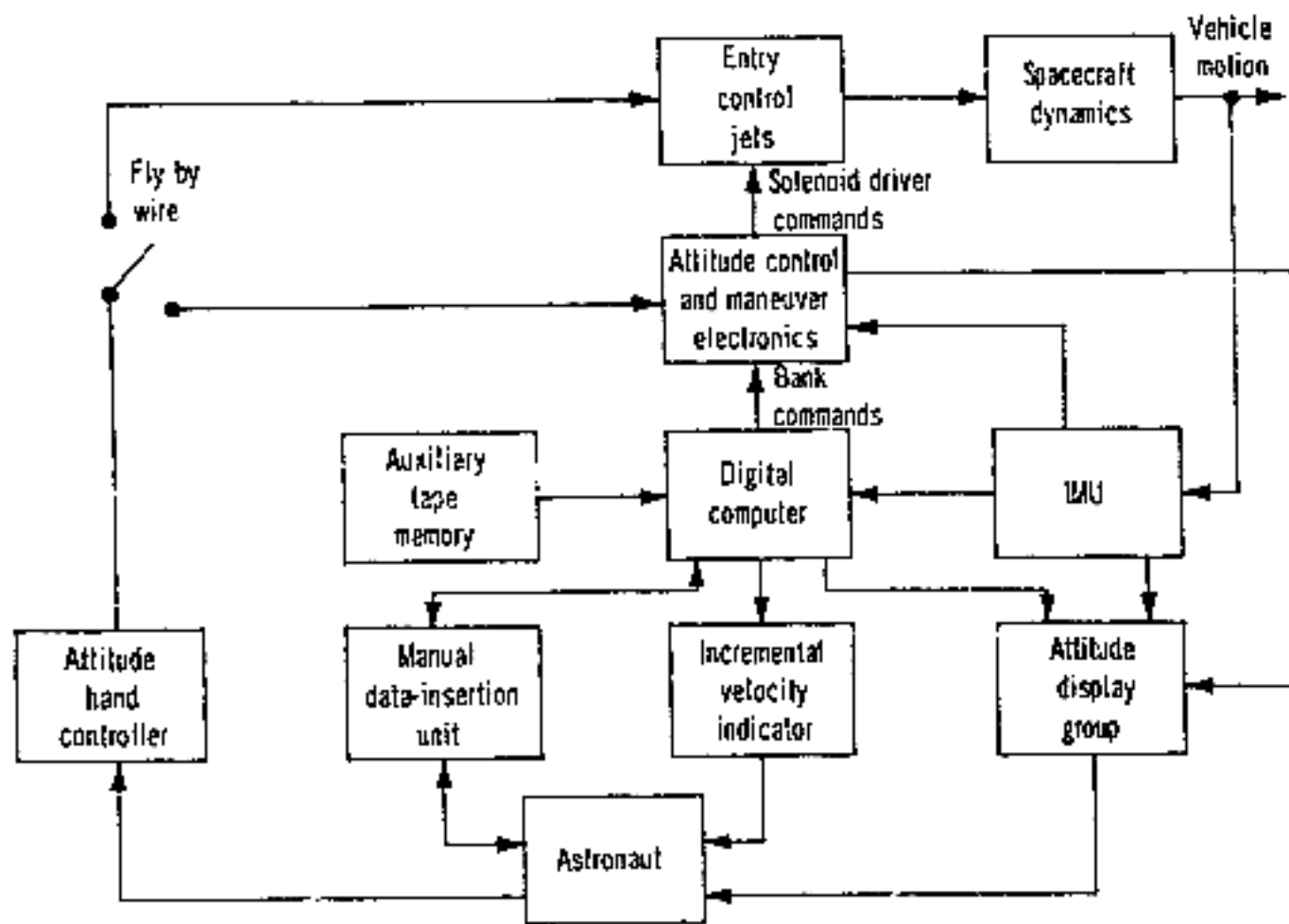
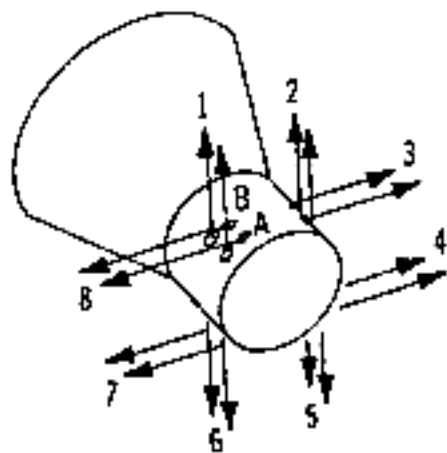

Figure 4.—Gemini entry G&C system.

The ACME received inputs from the hand controllers, the inertial measurement unit (IMU), and the digital computer. It processed these signals and sent firing commands to the appropriate thrusters. The system operated with on-off rather than proportional commands to the thruster solenoids. This arrangement allowed the use of simple switch actuation for manual control.

Rate signals were summed with the computer commands or IMU signals, and the output was also fed to the switch amplifiers. A logic block provided proportional coupling of roll rates into the yaw axis, which allowed coordinated maneuvers about the velocity vector during entry.

Two rings (A and B) of eight 25-lb bipropellant thrusters provided attitude-control torques about the spacecraft pitch, yaw, and roll axes during entry. Each ring of eight thrusters was supplied by an independent propulsion system. The 16 thruster locations and firing logic are shown in figure 5. Hypergolic propellants (monomethyl hydrazine and nitrogen tetroxide)



Attitude command	RCS jets fired
Pitch up	5 and 6
Pitch down	1 and 2
Yaw right	3 and 4
Yaw left	7 and 8
Roll right	3 and 7
Roll left	4 and 8

Figure 5.—Gemini entry-control jet configuration.

were used to insure fast propellant ignition. The following automatic and manual attitude- and rate-control modes were available during entry.

Rate-Command Mode

Rate-gyro outputs were compared in the ACME with hand-controller signals, and when the difference between the two signals exceeded the damping dead zone (± 0.5 deg/sec), the proper reaction jets were fired. It was not recommended that this mode be used during entry because of the high propellant usage due to small deadbands.

Direct Mode

This represented a backup control mode used to provide spacecraft angular acceleration by two methods. In the first method, switches on the hand controller provided on-off commands directly to the thruster solenoid valves. This mode was highly reliable because no electronic circuitry was required for its operation. In the second method, switches on the hand controller provided signals to the ACME, which were converted to on-off commands to the thruster solenoid valves.

Pulse Mode

The pulse mode was designed primarily to minimize propellant expenditure while performing attitude maneuvers in the absence of external disturbance torques. In this mode, a short-duration command signal was applied to the thruster solenoid valve when the hand

controller was deflected from its centered position. Pulses could also be obtained by using the pulse switches. The astronauts used this mode mainly between retrofire and the 0.05 g point to maintain the horizon in a specified orientation in the windows.

Entry Mode

The spacecraft pitch and yaw rates were automatically maintained within the damping dead zone (± 4 deg/sec) by the ACME. The electronic circuits of the pitch- and yaw-axis control were identical to those used in the rate-command mode except that commands were not accepted from the hand controller. Inputs from the guidance computer kept the spacecraft within 2 deg of the wind axis. A steady roll rate of 15 deg/sec was maintained for a zero-lift entry.

Entry-Rate Command Mode

This mode was used for manual entry-attitude control and had operational characteristics identical to those of the rate-command mode, except that the damping deadbands corresponded to the entry-mode values (± 2 deg and ± 4 deg/sec), and roll-rate crossfeed was included in the yaw channel as in the entry mode. This inclusion caused the spacecraft to roll about the velocity vector rather than about the spacecraft roll axis. The pilot could use the attitude display to follow the computer-generated roll angle.

2.2.2 Flight Experience

The Gemini Program included 10 manned space flights during which the entry-control system and its operational modes were thoroughly exercised and all design objectives were demonstrated. A summary of the entry-control modes used and pertinent flight experience on the manned missions is given in table II.

2.3 Apollo Entry Control

Although early Apollo flights were Earth orbital, the primary emphasis in the design effort was on the more critical lunar return mission. Information on the entry-control system is presented in references 18 to 29.

Table II.—Entry Control Mode Summary for Gemini Missions

Mission	Mode	Comment
3	Direct	Relatively high pitch and yaw rates (20 deg/sec)
4	Entry rate command	Computer failure during mission. Constant 15 deg/sec roll rate (zero lift) entry planned. After a roll rate was established additional buildup occurred because of a pitch thruster failure. Roll accelerations were produced as the pilot was damping initial pitch oscillations. Increasing roll rate caused increased yaw thruster activity to keep the yaw rate within the deadband. A maximum 65 deg/sec roll rate was reached approx 3 min before drogue chute deployment. Propellant almost depleted at this time. Jet interference of aerodynamic flow has been cited as probable cause.
5	Direct (approximately 3 min); rate command	One ring used. Propellant near depletion at drogue deployment because of using rate-command (low-deadband) mode.
6	Rate command	One ring used until all propellant was expended approximately 14 sec after max q . Second ring initiated before drogue deployment. Attributed to using low deadband mode.
7	Direct (approximately 57 sec); rate command	One ring depleted before 125 000 ft altitude. Other ring activated. Attributed to using low deadband mode.
8	Entry rate command	One ring depleted early in entry because the system was used after the separation from the Agena because of orbital system thruster failure.
9	Entry rate command	Nominal propellant usage.
10	Entry rate command	Nominal propellant usage.
11	Entry rate command (approximately)	First automatic entry control.
12	Entry	Nominal propellant usage.

2.3.1 System Description

The Apollo command module (CM), like that of Gemini, was a symmetrical body with an offset center of mass ($L/D \cong 0.28$). Control of the entry flightpath was accomplished by rolling the vehicle. Although direct entries were normally planned, the supercircular entry velocity could produce a skipout trajectory that constituted the critical design path for the entry-control system. The functional control requirements for a skipout entry are shown in figure 6. The control modes changed as a deceleration of 0.05 g was reached during the initial entry, skipout, and second entry. The entry-control system parameters and their defining requirements are presented in table III.

The overall G&C system for Apollo is shown in figure 7. Early flights in Earth orbit used the block 1 configuration. Subsequent flights used the block 2 system. In the block 1 design, the guidance-system signals went through the control system to operate the reaction-control jets. With the two systems connected in this series configuration, a failure in the control system would have incapacitated the guidance and navigation (G&N) system.

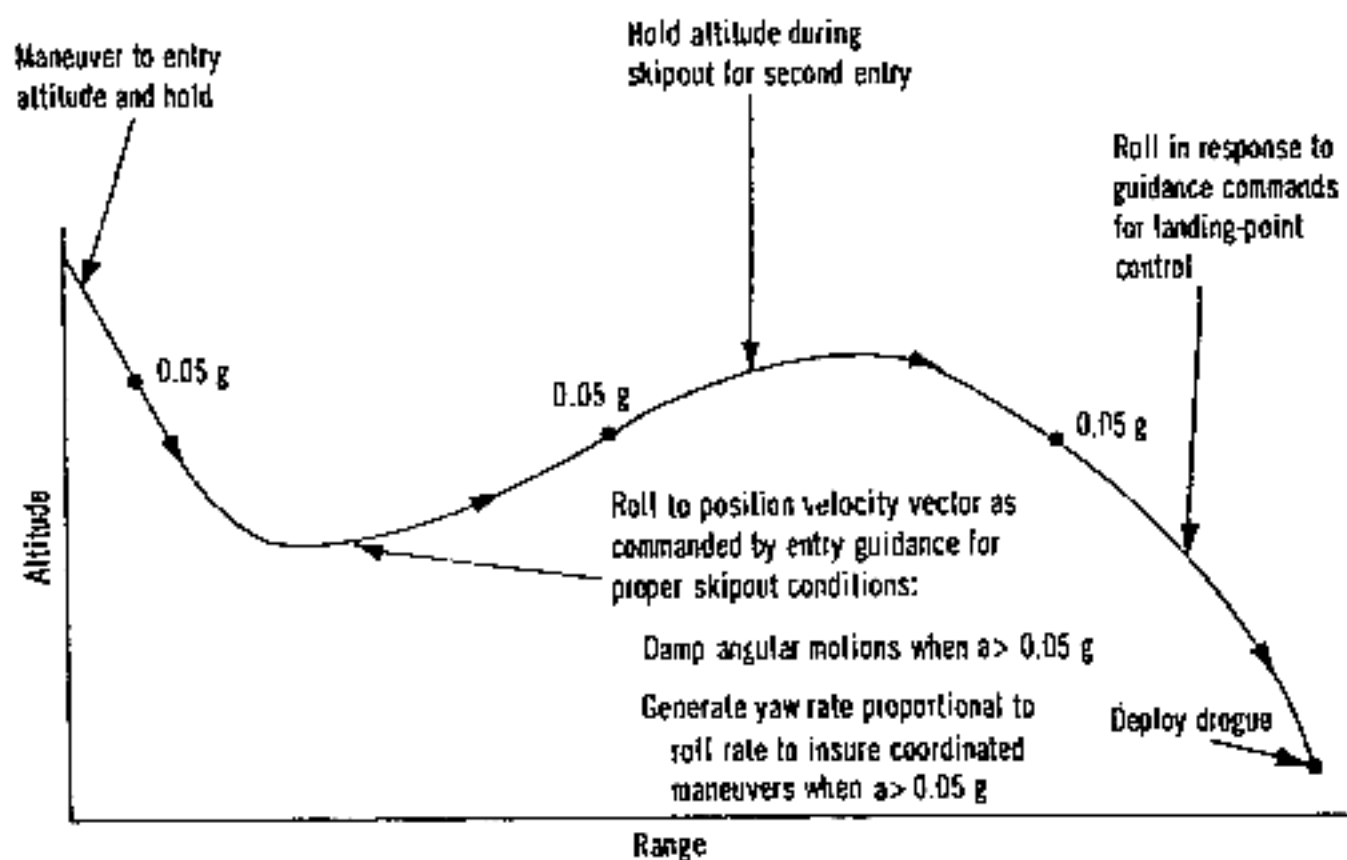

Figure 6.—Apollo entry-control functions for critical skipout trajectory.

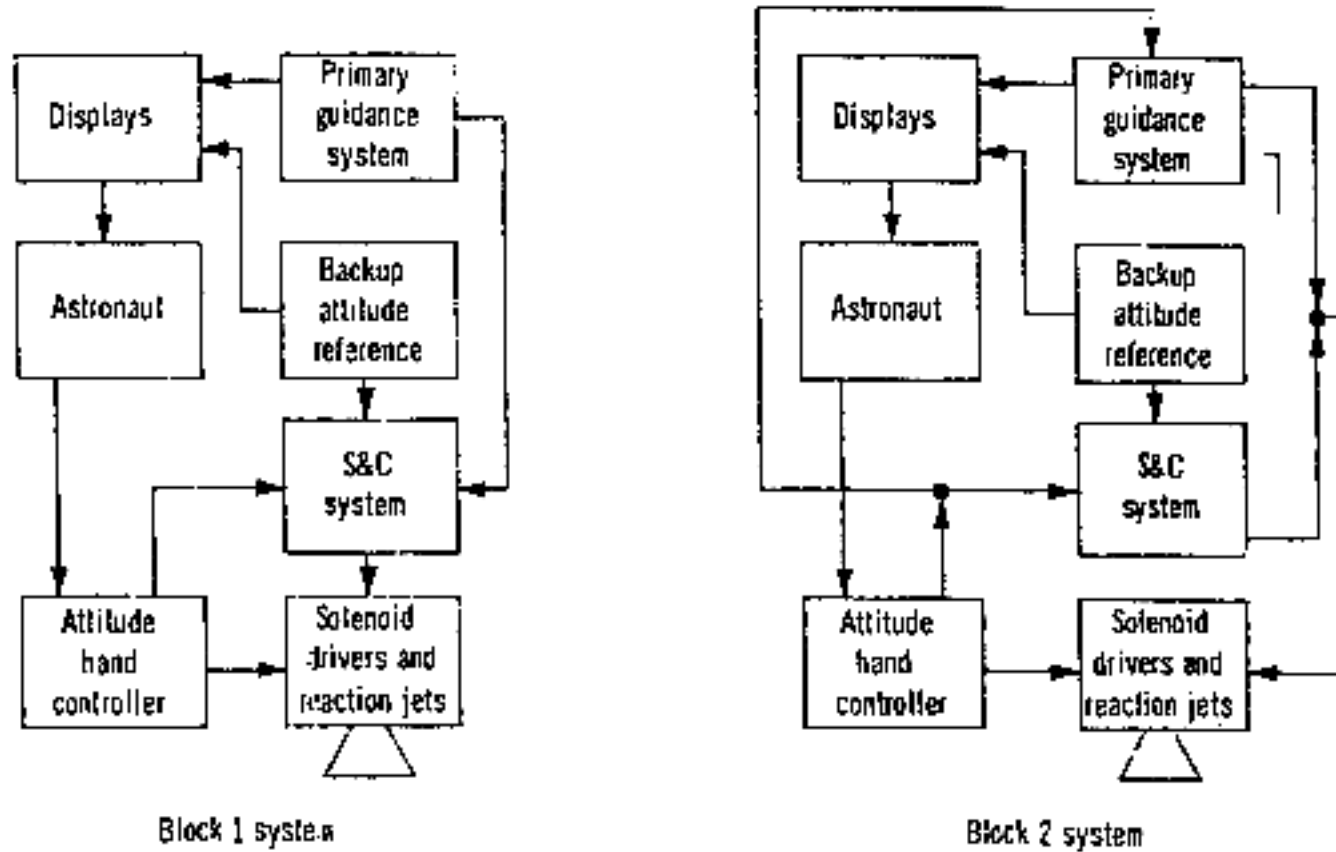

Figure 7.—Apollo G&C system designs.

Table III.—Apollo Entry Control System Requirements

Parameter	Value	Requirement
Rate deadband	2 deg/sec	Propellant minimization
Attitude deadband: Maximum	8 deg	Propellant minimization and attitude hold for preentry
Minimum	4 deg	
Rate-to-attitude gain	0.5–1/sec	Propellant minimization
Maximum commanded roll rate	22.5 deg/sec	Lift-vector orientation

The block 2 configuration, shown in figure 7, improved utilization of the two systems and made them electrically independent, so that a failure in one would not affect the other. In block 2, the G&N computer assumed the primary stabilization and control tasks. A manual and semiautomatic control system served as a backup to the primary system. With the backup attitude reference, the control system was sufficient to allow the crew to make a safe entry in the event of primary G&C system failure. The block 2 design illustrates the philosophy of using two nonidentical systems to achieve functional redundancy.

The entry-control system functional diagram is illustrated in figure 8. Attitude-error and rate-gyro feedback signals were limited to reduce the maximum maneuver rate in the interest of fuel economy. The output of the attitude hand controller was limited for the same reason. The switching amplifier and pseudo-rate logic provided an on-off pulse to the engine-select logic in response to the analog error signal input. The principle of operation of pseudo-rate logic is described in references 6 and 18. During entry ($a > 0.05 g$) and during manual maneuvers, the pseudo-rate feedback was switched out to prevent an overdamped response. The control pulse entered the jet select logic, whose primary function was to provide electrical isolation of the jet driver circuits. The solenoid drivers applied a fixed voltage to the engine-control solenoid valves. Each solenoid control valve had primary and secondary coils. The primary coil provided the normal driving force. The secondary coils

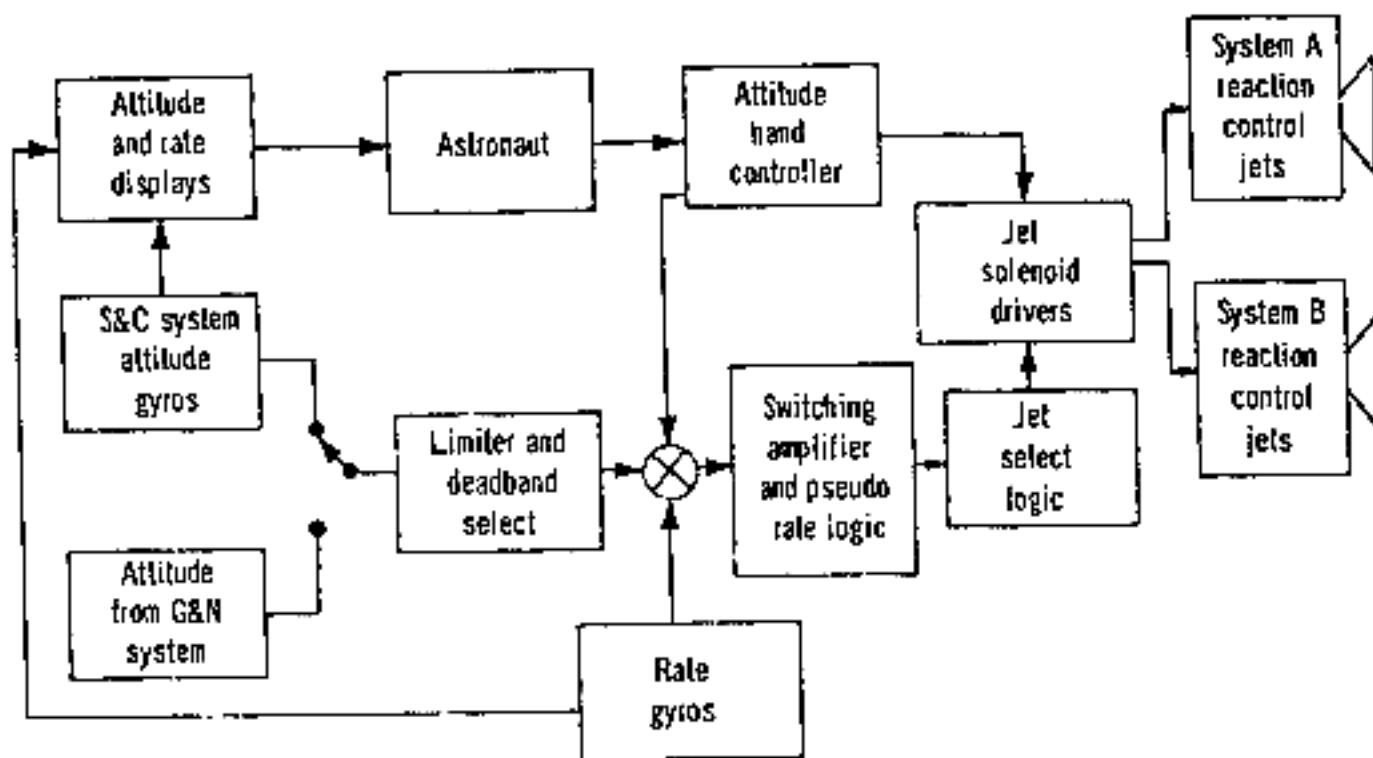

Figure 8.—Apollo entry-control functional diagram.

were connected directly to the attitude hand controllers and were powered directly from the battery, thus providing a highly reliable backup control mode.

There were three functionally identical reaction-jet control channels for roll, yaw, and pitch control. Vehicle attitude and rate were sensed by appropriate gyros, and signals were summed to drive switching amplifiers. Switching allowed an increase in the attitude deadband to conserve fuel when precise control was not required. For each channel, a switching amplifier drove a one-shot circuit that guaranteed a minimum time "on" command to the jet drivers. This arrangement eliminated the explosion hazard present from improper proportions of the hypergolic fuel and oxidizer. An additional coil on each solenoid valve was driven directly from switches near the end of travel of the three-axis attitude hand controller. These switches provide direct manual override in the event of failure of the automatic system.

Manual control of the vehicle was accomplished by summing signals from the hand controller and signals from the rate gyros to command the jet drivers. Miscellaneous switching functions provided for disabling the attitude reference, the hand control, or the jet drivers under certain conditions. Provision was also made for direct input commands from the guidance computer to the jet drivers.

Instrumentation and displays included a flight direction attitude indicator (FDAI), three needle-type indicators that displayed computed attitude error in body axes, and three needle-type displays of spacecraft rotational rates. The FDAI consisted of a servo-driven gimballed ball with full and continuous rotational capabilities for display of pitch, yaw, and roll.

The two identical and independent jet-thruster systems (A and B) are shown in figure 9. Both systems were operated simultaneously, but each system had the capability of providing the impulse required to perform the necessary preentry and entry maneuvers. The minimum impulse that could be provided by a thruster was 2.0 lb-sec. Each jet developed 100 lb of thrust.

2.3.2 System Operation

The modes of entry control are shown in figure 10. Automatic modes were available through the digital autopilot (primary) and the control system. Attitude information was obtained from the IMU. Rate information was obtained by differentiating the IMU gimbal angles in the CM digital computer. Thruster commands for attitude-hold or maneuvers were determined by logic in the computer.

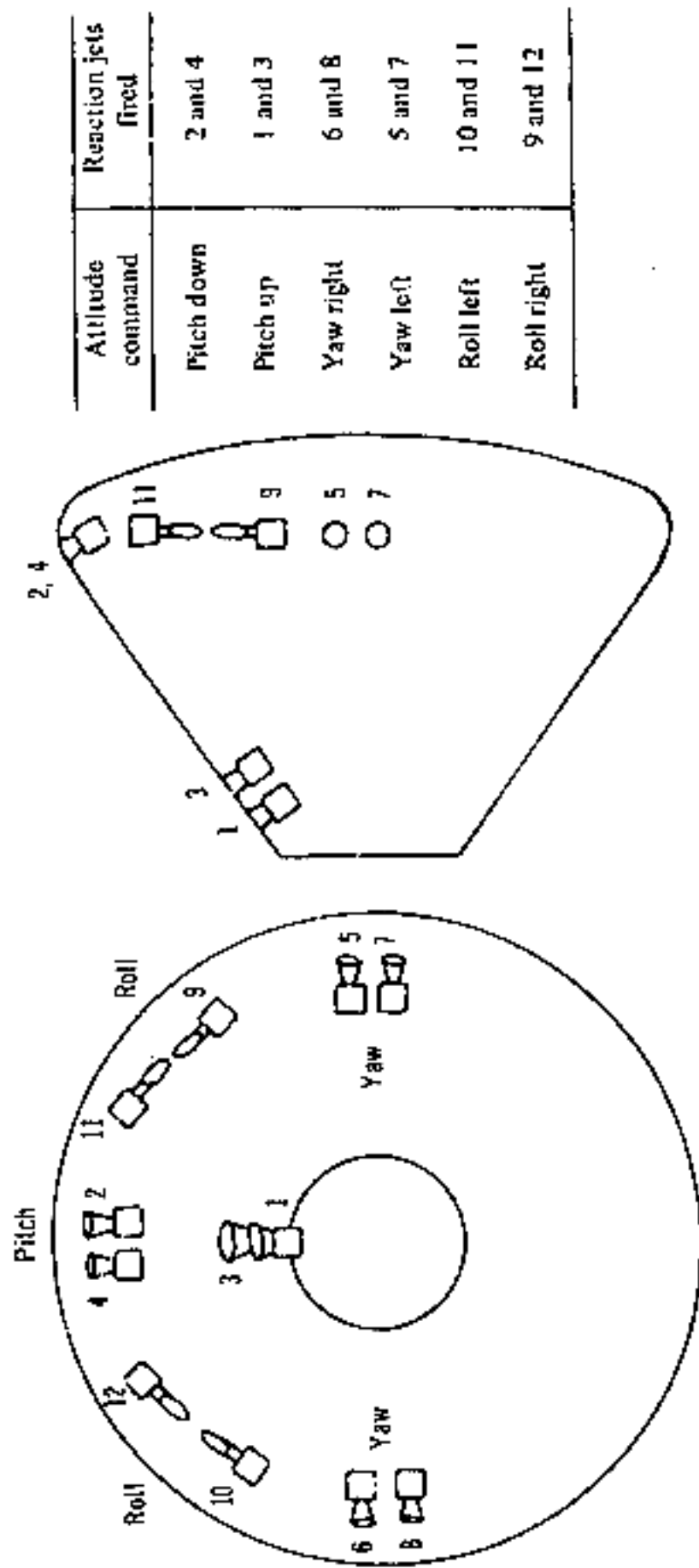

Figure 9.—Apollo CM reaction-jet control system.

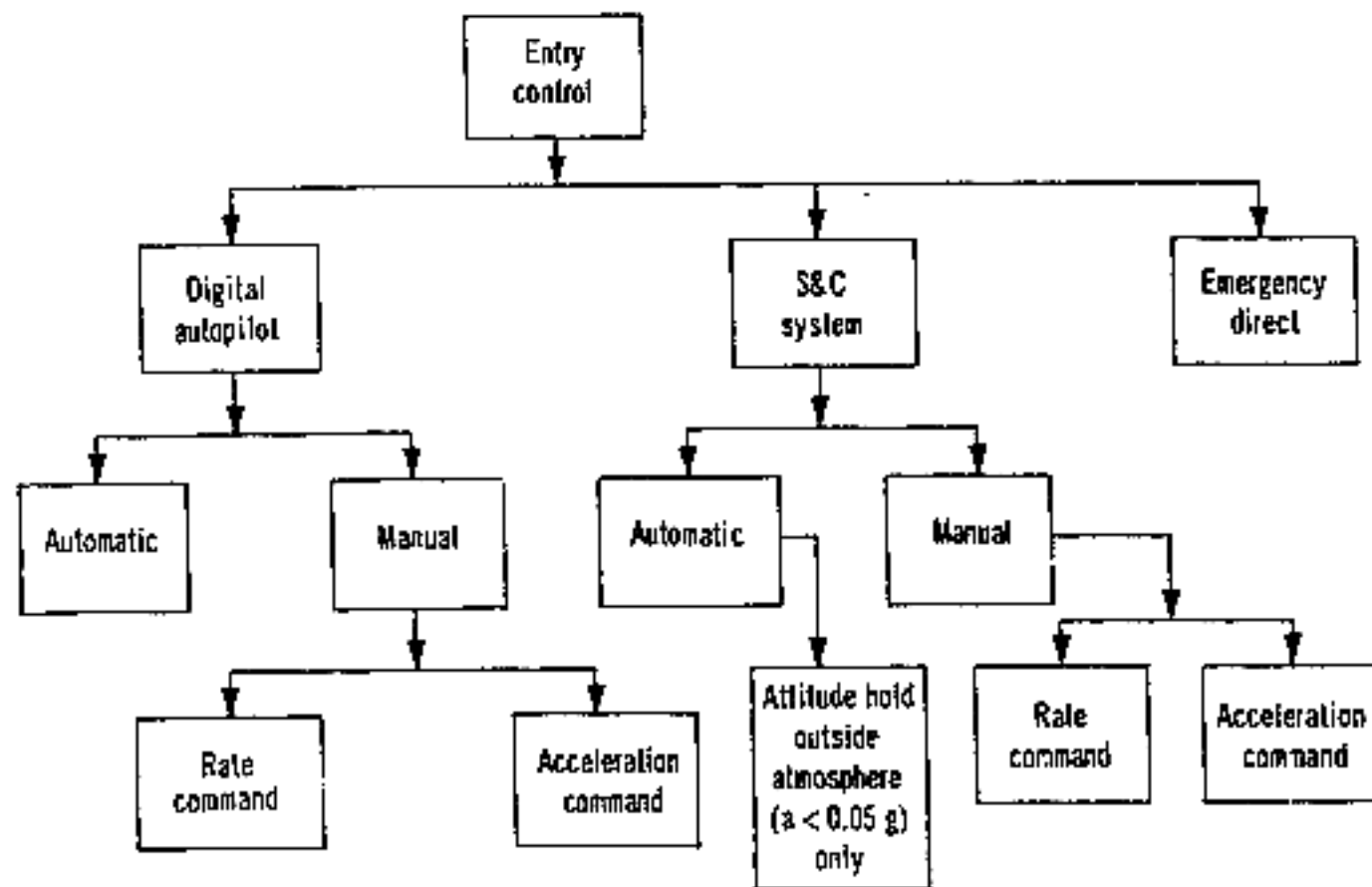

Figure 10.—Apollo entry-control modes.

In the backup control system, attitude hold was accomplished by an analog system using the body-mounted attitude gyros for attitude information and the rate gyros for rate information when acceleration was less than 0.05 g. For entry ($a > 0.05$ g), roll commands for lift-vector control were generated manually by using the entry monitoring system for visual cues. Pitch and yaw rates were damped automatically.

An emergency mode bypassed the control-system electronics and drove the reaction-jet valves directly. The resolution in attitude rate under manual control was about ± 0.5 deg/sec. Rates up to 25 deg/sec could be commanded. During the automatic attitude-hold mode, the control system was capable of achieving a limit-cycle amplitude of ± 0.5 deg. The deadband could be changed to ± 5.0 deg to conserve propellant. Drift rates of less than 0.2 deg/sec about all three axes were expected. During entry ($a > 0.05$ g), the computer generated thruster commands to achieve the vehicle attitude required for reaching the desired downrange and crossrange impact point.

2.3.3 Flight Experience

Available reports on the first five Apollo missions include references 26, 27, 28, and 29. The planned entry trajectory for Apollo 7 differed slightly from the actual one, because the lift

vector was held at a 55 deg roll-right attitude 60 sec longer than planned. Manual control was used down to about 20 000 ft on Apollo 7. Control was then turned over to the digital autopilot. Figure 11 shows the propellant used during entry. The crew switched to dual reaction-control system operation as shown on the figure after reporting a large, unexplained pitch disturbance. The commanded and actual roll angles, shown on figure 11 as functions of time, indicate proper response of the spacecraft to the bank-angle commands.

Considerable pitch and yaw control activity occurred in the transonic region during the final 2 min before drogue deployment on Apollo 7. Ground simulation indicated that this activity was the result of thruster-jet interactions with flow around the vehicle and of strong winds.

In later flights, Apollo 8, 9, 10, and 11, the entry-attitude control performed within nominal limits. Automatic control, with the digital autopilot, was the mode primarily used.

2.4 X-15 Entry Control

Three X-15 aircraft were used in a flight test program extending from 1958 to 1968. One of the objectives of the program was to develop and test entry-control systems for manned vehicles. Information on the entry-control systems, contained in references 30 to 50, is summarized.

2.4.1 System Description

The X-15 aircraft were single-place, rocket-powered vehicles that were launched from a B-52 aircraft and self-propelled to altitudes up to 350 000 ft. They returned into the atmosphere without thrust at mach numbers over 6. Entry presented severe control problems because of the rapid increase in dynamic pressure. More than 190 research flights were made with the X-15 airplanes, using four modes of reaction control and three modes of aerodynamic control, and two airplane configurations (ventral fin on, and lower ventral fin off). When the original ventral-fin-on configuration exhibited undesirable augmentation-off control characteristics, the lower fin was removed. The stability and control and physical characteristics of these configurations are presented in detail in references 30 through 35.

Both movable aerodynamic surfaces and jet thrusters were used to provide control torques. The two systems had nearly equal effectiveness when the dynamic pressure q was 10 lb/ft², but the pilots used the jet thrusters at much higher values of q because they produced pure torques about each axis (e.g., the ailerons, while producing mainly roll torque, also

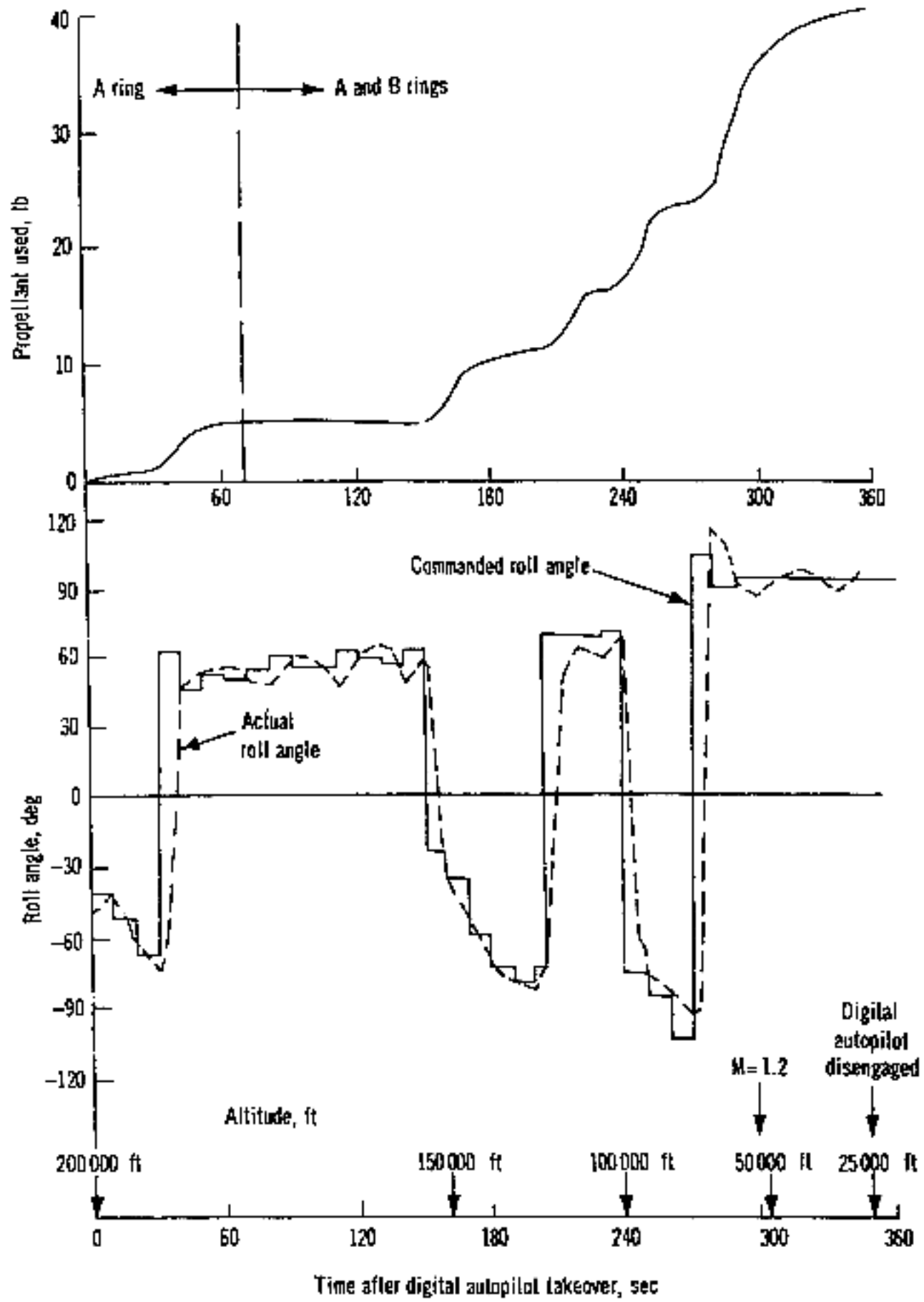

Figure 11.—Apollo 7 entry data.

produced significant yaw torque). Two of the X-15 airplanes were equipped with three-axis stability augmentation. The other airplane had an adaptive rate-command-control system, designated the MH-96 system. Figure 12 presents the location of the control-system components in the vehicle. The control system is described in detail in reference 36. The reaction-jet thrusters provided a roll acceleration of 5 deg/sec^2 , and pitch and yaw accelerations of 2.5 deg/sec^2 for each of two systems. For pilot safety, two identical control systems were provided which operated in parallel.

Stability-Augmentation System

A functional diagram of the stability-augmentation system (SAS) is presented in figure 13. The system, described in references 36 and 37, consisted of an electronic network or channel for each axis. This network sensed the aircraft rate of change of pitch, roll, and yaw and automatically provided signals to the respective servocylinders that caused the surface actuators to move the horizontal and vertical stabilizers to oppose the airplane angular rates. Individual servocylinder outputs and the pilot's manual inputs were combined to form a single input to the surface actuators. The pitch and roll channels operated singly or in combination at the pilot's discretion. Because the horizontal stabilizers were used for both pitch and roll control, the left and right servocylinders controlled the stabilizers for both

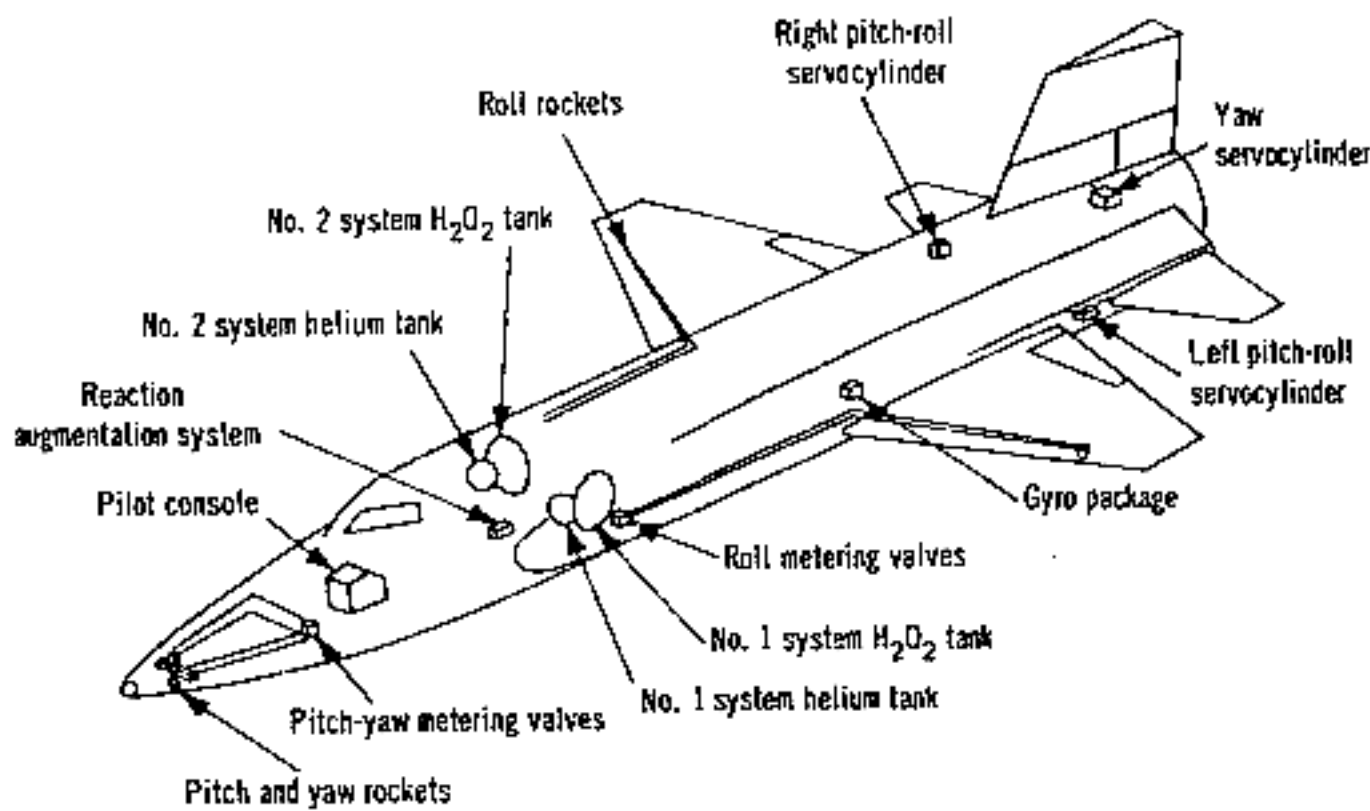

Figure 12.—Location of control-system components in X-15.

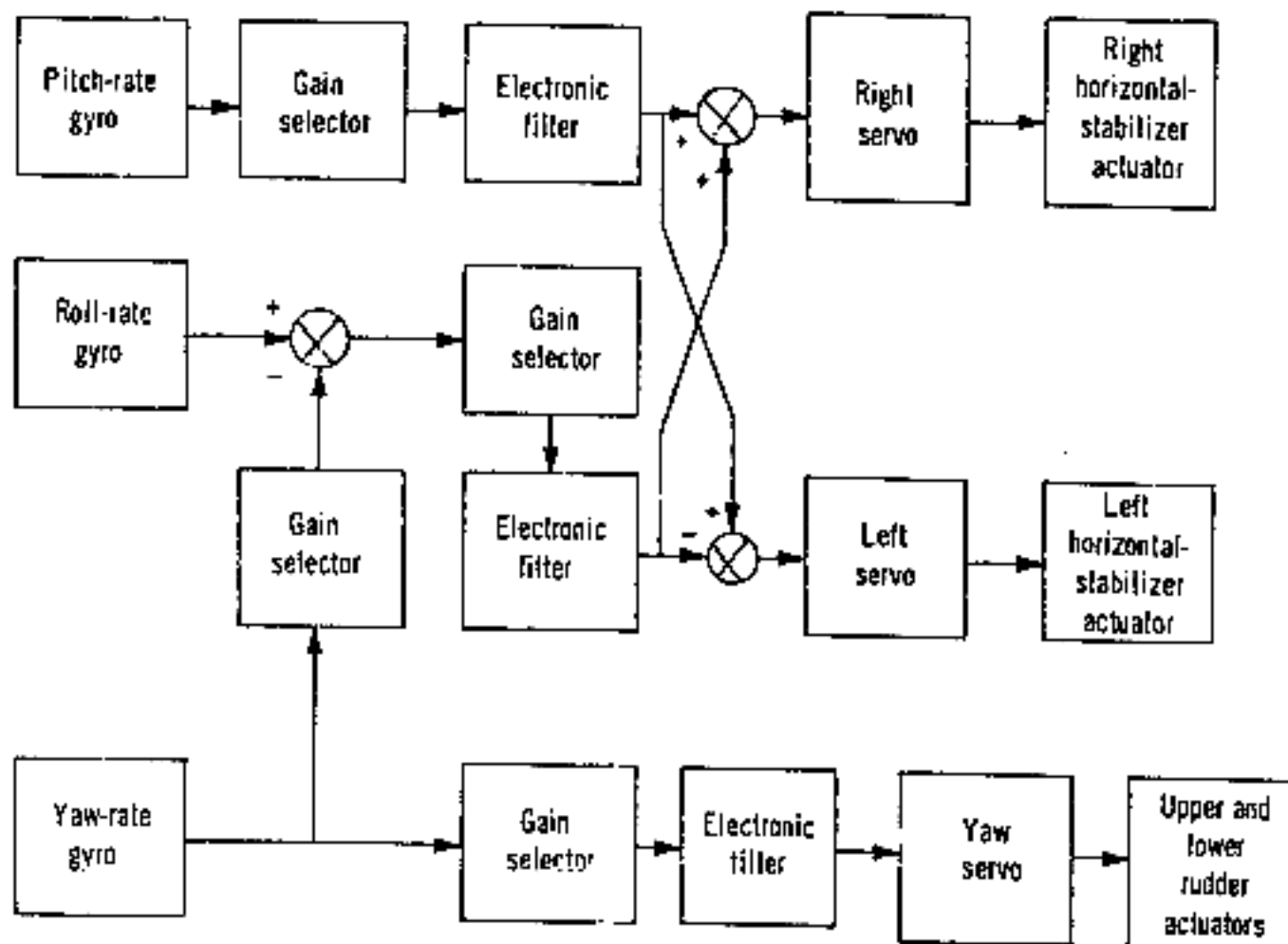

Figure 13.—Functional diagram of the stability augmentation system (SAS).

pitch and roll damping. The yaw channel operated independently of the pitch and roll channels. The pilot had on-off and feedback gain control of the SAS, which enabled him to vary the gains throughout the flight envelope.

The working channel drove the servocylinders. The monitor channel operated electronically simulated servocylinders, and compared the outputs to those of the working channel. When the difference between the servocylinder position and the simulated servocylinder position exceeded 10 percent in any channel, a failure was signaled and the servocylinder centered and locked, disengaging the SAS. Differences could occur because of electrical or mechanical malfunction.

MH-96 Adaptive Control System

The adaptive flight-control system (refs. 38 to 40) used on one of the aircraft was a

model-following rate-command system. A block diagram of the system is shown in figure 14. This diagram is for the pitch axis but is typical of the roll and yaw axes. The principal features of the system were self-adjusting gains, rate-command control by the pilot, hold or attitude command modes of operation, normal-acceleration command and limiting, and automatic blending of aerodynamic and jet reaction controls.

The system was installed so that the mechanical connection linking the pilot's control stick with the surface actuators was unaltered. Manual control of the unaugmented airplane was unchanged.

With the airplane stability augmented by the autopilot, input was shaped by a model to give the desired response. A rate-gyro signal that represented the actual airplane response was compared with the shaped pilot input. The signal difference was then driven to zero by a high-gain forward loop. The servo feedback signal was filtered, rectified, and compared with a set point. The sign of any difference was used to raise the gain if the servo motion was less than desired and lower the gain if the servo activity was greater than desired.

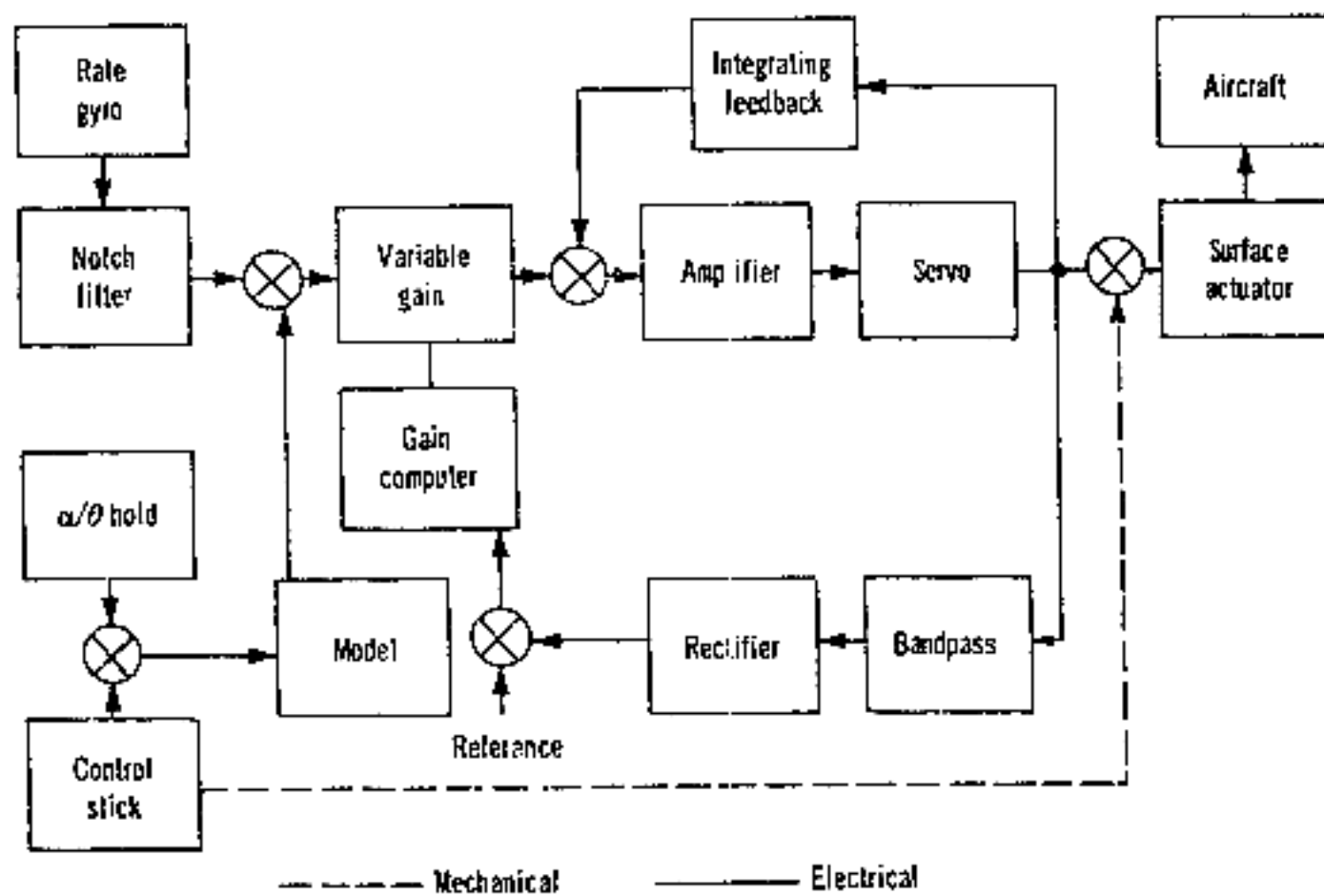

Figure 14.—MH-96 adaptive control-system pitch mode.

Reaction-Control System

Four types of reaction-control systems were used on the X-15 (ref. 41). The basic reaction-control system was a pure thrust-command system, but with thrust proportional to stick deflection outside of a dead zone of 15 percent of stick travel. A second type of system was provided by modifying the basic reaction-control system to include reaction-rate damping. Two types of reaction control were available to the pilot with the MH-96 control system: a rate-command reaction control for manual control, and an attitude-hold control loop.

The reaction-control system consisted of two independent, parallel propellant and rocket systems operated simultaneously by a single three-axis controller. Although satisfactory attitude control could be maintained with a pure thrust-command system, the pilot had to give considerable attention to the control task. To decrease the X-15 piloting task in the low-dynamic-pressure flight regions, an automatic reaction-augmentation system (RAS) was incorporated into the basic reaction-control systems on two aircraft. The RAS was added to only one of the two parallel reaction-control systems on each aircraft, which, in effect, limited the RAS control authority to one half that available to the pilot, who had command over both systems.

A block diagram of the RAS is presented in figure 15. The RAS consisted of three rate gyros, located to sense the aircraft's rotational rates about all three body axes. The gyros converted the vehicle's angular rates to proportional electrical signals, which were amplified in the electronics section of the assembly. The signal was then used to operate an on-off solenoid control valve that controlled the flow of propellant to the rocket motors. Switches on the controller linkages prevented opposing inputs from occurring between the RAS and the pilot. An accelerometer unit was used to provide a signal to automatically disengage the system during entry after normal aerodynamic effectiveness was reestablished.

2.4.2 Development and Flight Experience

The major entry-control system problems encountered during the X-15 development and flight test program are discussed in references 42 through 50.

Limit Cycles

During early flights it was found that the SAS of X-15 caused the vehicle to oscillate at a small amplitude and at frequencies up to 3 Hz (ref. 42). These limit cycles were most noticeable in roll and were caused by the phase lag of hysteresis and other nonlinearities in the mechanical portion of the control system. Although, in general, the limit cycles were

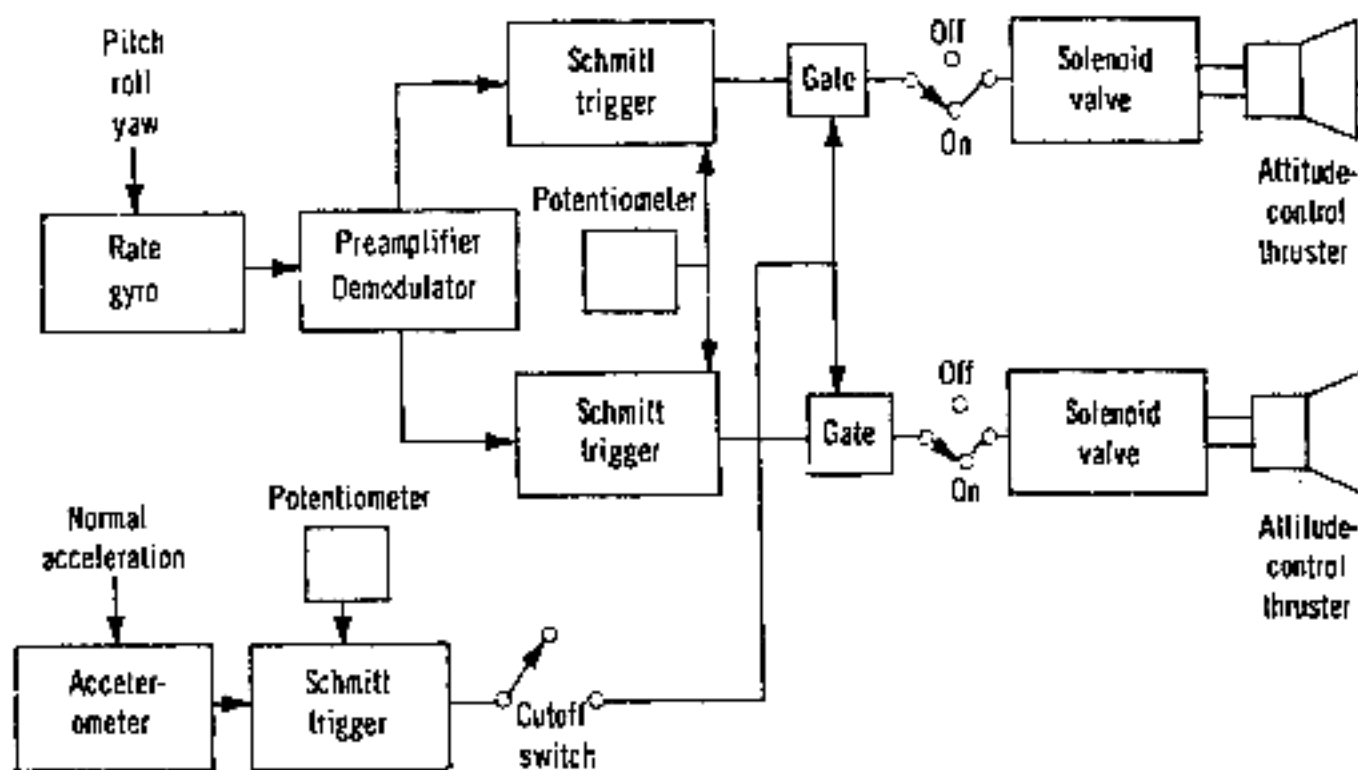

Figure 15.—Typical axis of X-15 reaction augmentation system.

only annoying to the pilot, analysis and experience showed that with the original electronic filter, the limit-cycle amplitude in roll abruptly increased at certain values of loop gain and could cause loss of control. Efforts to alleviate the problem by reducing the amount of hysteresis were not successful. The problem was solved by using an electronic filter that reduced the phase lag in the system during flight. A resonance problem still existed during ground tests, however, which made it necessary to reduce the SAS gains while the vehicle was on the ground.

Structural Resonance

This problem induced by the SAS was encountered only after the electronic filter was changed to solve the limit-cycle problem. The problem appeared as a severe in-flight vibration of approximately 13 Hz at 170 000 ft altitude and a dynamic pressure of 100 lb/ft². The vibration was limited in amplitude because of the rate limit (25 deg/sec) of the control-surface actuator. The pilot stopped the vibration after about a minute by reducing the pitch SAS gains. A notch electronic filter for the SAS was designed to give minimum phase lag at limit-cycle frequencies and a maximum of attenuation at the natural frequencies of the structure. The filter successfully eliminated surface resonance and alleviated the limit-cycle problem. However, small-amplitude limit cycles persisted at some

flight regimes. As a result of the flight experience with the modified filter, it was clear that both limit-cycle problems and structural coupling have to be considered simultaneously in the selection of acceptable control-system filters.

Pilot/Vehicle Lateral Control Instability

This phenomenon was observed with the X-15 simulator and later confirmed in flight through closely controlled tests (ref. 43). Attempts to control bank angle with normal use of aileron resulted in divergent oscillations in sideslip and roll, although the basic airplane was considered statically and dynamically stable. During studies of the problem, in which the X-15 flight simulator was used, it was learned that an important area in the flight envelope was uncontrollable without dampers. In this area, the vehicle seemed to the pilot to be dynamically unstable.

An analysis of this instability revealed the cause to be an unfavorable combination of the yawing moment caused by aileron deflection and the dihedral effect, which was subsequently alleviated by removing the lower moveable ventral. The change, although producing lower static-directional stability and rudder effectiveness, resulted in a more controllable airplane with damping augmentation inoperative, particularly at high angles of attack. The studies of the problem indicated that extensive flight simulator tests are necessary to define adequately the vehicle controllability boundary and the augmented damper requirements.

System Saturation Instability

Early in the design of the adaptive controls, it was recognized that high rate commands from the pilot could not be followed by the control-surface actuators. Servo motion would be reflected back to the pilot's stick as stick kicks, and system instability would be experienced because of the inability of the system to follow the commanded rate. For nearly 40 flights, rate-limit problems were not encountered, even during entries from the highest altitudes. However, the problem was experienced during a relatively routine flight and the airplane became uncontrollable in roll for a short time. The flight record indicated that the servo rate limit had been exceeded.

The incident (ref. 47) was initiated by a rather modest pitch-control command with some roll command by the pilot. The resulting rate limiting of the servo produced sufficient system lag to reduce the pitch-damper effectiveness and to cause the roll-command system to go unstable. Reduced commands and adaptive gains restored the system to operational status, and the airplane motions were again damped. Analysis of the problem showed that the system nonlinear instability was caused by rate-limit-induced lag at low frequencies. The problem was solved by including a simple lag-lead circuit in the servo loop to reduce the lag at the critical low frequencies.

Loss of Control

The 191st X-15 flight encountered loss of control during entry, which resulted in loss of the aircraft and pilot (ref. 50).

The accident was precipitated during the ballistic portion of the flight when the pilot allowed the airplane to deviate in heading and subsequently flew the airplane to an extreme attitude with respect to the flightpath that there was loss of control during the entry portion of the flight. Destruction of the aircraft resulted from divergent aircraft oscillations that caused the aircraft's structural limits to be exceeded.

Additional information regarding the experience with the MH-96 Adaptive Flight Control System will be found in a forthcoming NASA Technical Note, "The Experience With the X-15 Adaptive Flight Control System," Staff, Flight Research Center.

Pilot Opinion

All the X-15 pilots endorsed the blending of aerodynamic and reaction controls activated by the same controller. The proportional-thrust command reaction control was not appreciated by the pilots, nor did they use the control as a proportional-control device. In all instances, it was used as an on-off control. The use of rate-command reaction controls resulted in much more precise control and apparently consumed less fuel. The reaction augmentation was appreciated by the pilots. The pilots used reaction controls to dynamic pressures several times higher than expected. This practice resulted in the use of more reaction-control fuel during several entries than predicted or designed for. The deadband design of 15 percent of stick deflection was considered excessive by the pilots.

2.5 ASSET Entry Control

The unmanned Aerothermodynamic/elastic Structural Systems Environmental Tests (ASSET) entry vehicle configuration consisted of a flat-bottomed, 70° delta wing and a cone cylinder body on the upper surface. The vehicle maximum L/D was 1.2 and the $W/C_D A$ was 250 lb/ft². A liquid-ballast system transferred liquid mercury between forward and aft tanks to change the vehicle center of mass and hence the trim angle of attack. Control forces were provided by hydrogen peroxide jets which were activated by signals from the control-system electronics. Detailed data on the entry-control system may be found in references 51 and 52. Data regarding related systems, SLAMAST (Scout Launched

Advanced Materials Test Bed) and another mass shift control concept, are given in references 53 and 54, respectively.

A functional diagram of the ASSET G&C hardware (a modified Scout system) is shown in figure 16. During the transition phase, when the control system helped the vehicle to attain trim angle of attack for glide, the pitch-control loop used attitude and rate feedback with deadbands of ± 0.8 deg and ± 2 deg/sec respectively, in conjunction with a 40-lb-thrust pitch down jet and a 2-lb-thrust pitch up jet. The roll system employed deadbands of ± 0.8 deg for position and ± 2 deg/sec for rate in conjunction with 15-lb jets. The yaw deadbands for the entire flight were ± 0.4 deg for position and ± 1 deg/sec for rate.

At the start of glide, active pitch-position control was discontinued, and a pitch-rate damper system having a ± 1 deg/sec deadband was used to attenuate large oscillations about the vehicle trim. Two-lb thrusters were used for damping. During the glide phase, for periods of sufficient roll airframe stability, a wide position deadband of ± 6 deg was used with a ± 4 deg/sec rate deadband, and during periods of marginal lateral-directional vehicle stability, a narrow deadband of ± 0.8 deg for position and ± 2 deg/sec for rate were used. At various

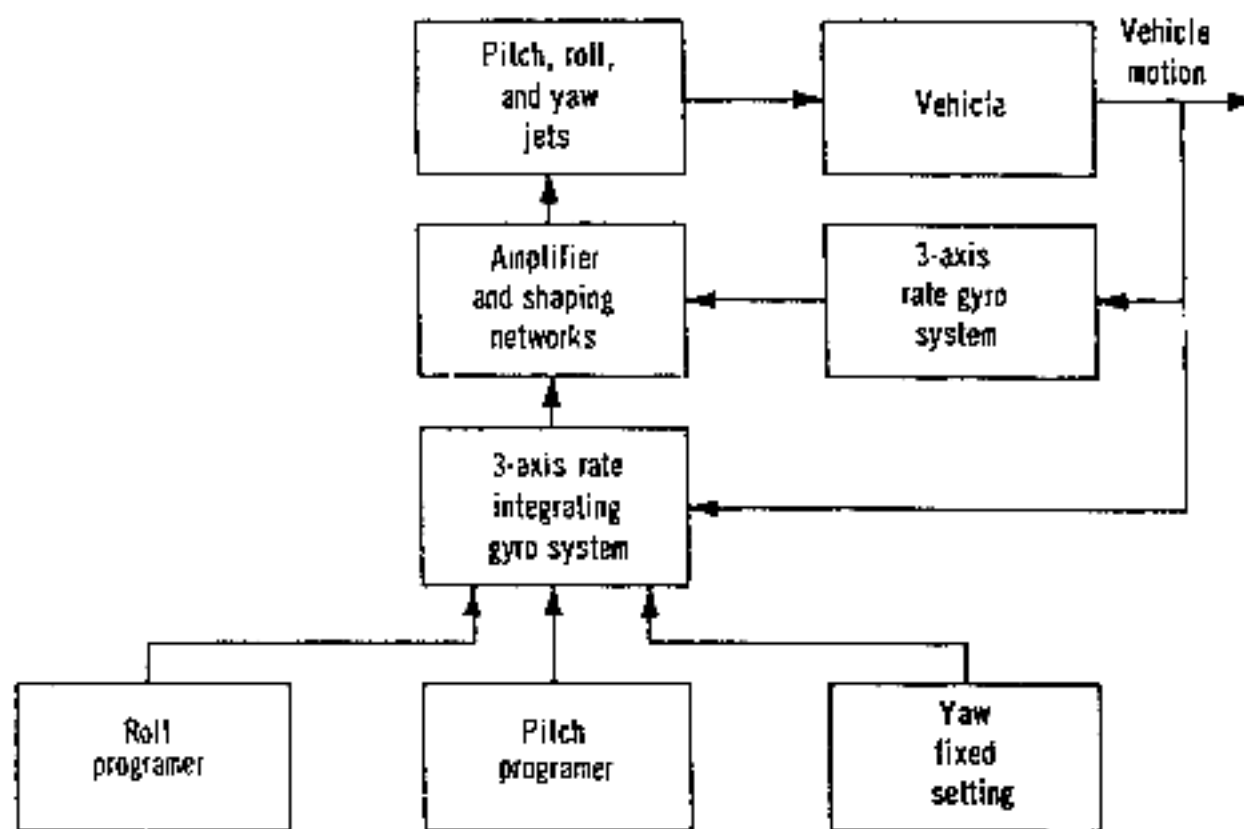

Figure 16.--ASSET guidance and control system.

times during the flight, depending on the predicted dynamic pressure, vehicle characteristics, mach number, and angle of attack, the roll and yaw jets were switched between the 5- and 15-lb thrust levels.

The entry-control system performed satisfactorily during five suborbital ASSET flights, maintaining flight attitude within 3σ design limits down to recovery-system deployment. The only flight malfunctions were intervalometer timing errors that occurred during the AEV-1 and AEV-3 flights. The problem was found to be caused by radiofrequency interference on the input power leads. Ground testing revealed several problems that were primarily component failures. These malfunctions occurred in the intervalometer, poppet-valve electronics, and in the stabilization unit. Descriptions of these failures and conclusions drawn therefrom are given in reference 51.

2.6 PRIME Entry Control

The unmanned Precision Recovery Including Maneuvering Entry (PRIME) flight test program was conducted to demonstrate the feasibility of a maneuverable vehicle capable of recovering a small payload from low Earth orbit. Three flights were made using an SV-5D entry vehicle with a maximum L/D of 1.1 and $W/C_D A$ of 175 lb/ft². Pitch control by means of a pitch flap provided downrange control. In addition, reaction jets provided control in pitch, roll, and yaw.

A functional diagram of the PRIME G&C system is shown in figure 17. The modulation of L/D in the pitch plane controlled range of the vehicle. Modulation of the lift vector in the roll plane controlled crossrange maneuvering. Very little information on the PRIME control-system description and performance is available in the unclassified literature. Some data are presented in references 55 and 56.

2.7 Future Trends and Summary

Considerable technical literature exists on attitude-control systems not directly related to the space flight programs discussed previously (for example, refs. 54 to 72). Emphasis is currently being placed on the development of man-rated systems that are reusable without major refurbishment, and systems that are versatile and adaptable to a variety of missions.

Several significant developments and trends have occurred during the evolution of manned-spacecraft entry-control systems.

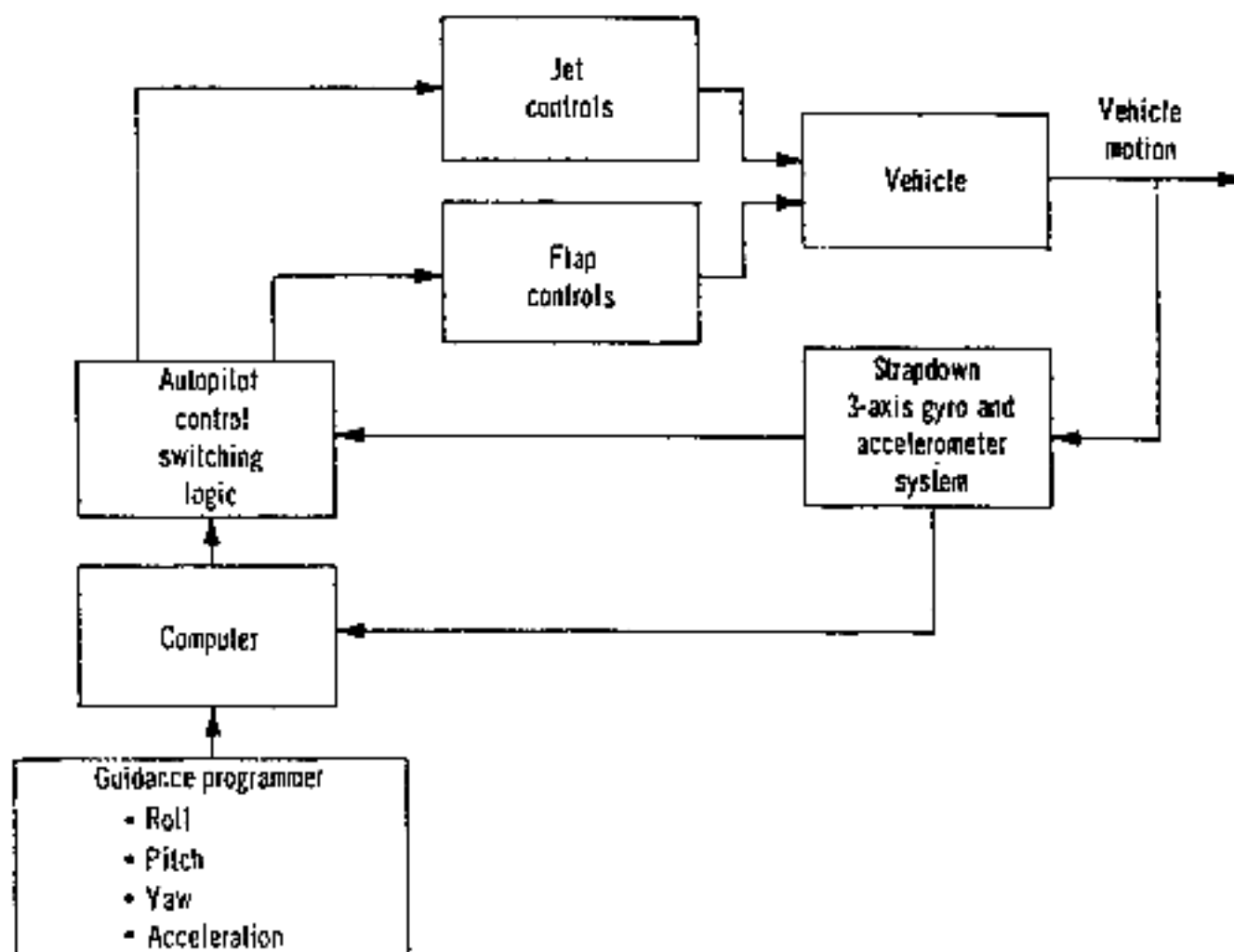

Figure 17.—PRIME entry G&C system.

The astronaut has been affirmed as the final control-system backup mode. Experience has shown that provisions for manual control significantly increase mission reliability. Provision for direct and fly-by-wire manual control and associated instrumentation and display has been made in all manned spacecraft to date.

Current manned spacecraft use high-energy, fast-igniting hypergolic propellants, stainless steel propellant-supply systems with helium pressurization, and thrust controls employing on-off solenoid valves. Reliability has been the primary consideration in these choices.

Thruster switching logic has received much attention to reduce propellant consumption and to improve the capabilities of attitude hold and rate command. Pulse-width, pulse-frequency modulation is currently in use, with consideration being given to nonlinear pulse-ratio modulation for future systems.

The use of digital adaptive-control systems is increasing as improvements are made in the onboard computer capabilities and in the hybrid systems necessary for this application.

A concept of functional redundancy has emerged that does not require provision for spares or replacement parts to be carried along on a mission. Instead, the original design incorporates two nonidentical systems that overlap functionally, so that in case of the malfunction of one, the astronauts can complete the mission with the other. This philosophy is exemplified in the design of the block 2 Apollo guidance, navigation, and control systems.

For vehicles that include moveable aerodynamic-control surfaces and reaction controls, pilot preference is for automatic blending with actuation by the same hand controller.

3. CRITERIA

The control system shall be designed to allow the entry vehicle to acquire and maintain the desired flightpath under all anticipated mission conditions. An acceptable compromise among performance, complexity, power consumption, propellant expenditure, weight, volume, and reliability shall be achieved. The entry-control system shall be as insensitive as practicable to off-nominal atmospheric and initial entry conditions and variations in vehicle aerodynamic and mass characteristics. Crew safety shall be accorded first priority in design decisions; however, appropriate emphasis shall be given to mission objectives.

3.1 Performance

It shall be demonstrated that control moments are adequate to maintain vehicle attitude and to provide maneuvering rates required by the mission.

The entry-control system shall provide attitude control and maneuvering rates with specified accuracies.

The entry-control system shall be stable. For any allowable set of initial conditions, the deviations from the commanded flightpath and attitude should become or remain smaller than acceptable bounds established by mission requirements. The closed-loop response shall exhibit adequate damping and acceptable natural frequencies.

The entry-control system shall be designed to be as insensitive as possible to changes in vehicle characteristics, control-system hardware, guidance requirements, and environmental changes.

The control system should not excite vehicle structural oscillations that will impair flightworthiness.

The control logic should be as simple as possible to perform the required functions. It should require as little computation time as practicable consistent with performance requirements.

The reaction-jet fuel allotted for entry shall be commensurate with the required control accuracy and safety.

The control system shall be capable of maintaining the vehicle attitude within specified attitude boundaries consistent with vehicle load and heating constraints. The total number of jet firings required for control during entry shall be compatible with duty cycle, fuel reserve and endurance limits of the thrusters.

3.2 Crew Safety and Flightworthiness

The designer must quantitatively demonstrate with a high level of confidence that no characteristic of the entry-control system could compromise crew safety or impair flightworthiness. The demonstration shall be validated through a series of analytical studies, component tests, system tests, simulations, and flight tests. All anticipated configurations, missions, flight conditions and-system modes of operation shall be considered.

Failure of any individual component or subsystem shall not prevent safe completion of entry.

Equipment reliability shall meet specified mission requirements.

Malfunction-detection and system-monitoring equipment shall be provided to enable the crew to recognize the need for a mode change prior to and during entry. All monitors and controls shall be simple, functionally straightforward, and readily identifiable to facilitate rapid and accurate crew performance.

All controls, switches, and displays should be designed to insure operation in the intended manner. Interlocks should be provided to prevent inadvertent mode switching or other improper operation. Positive safeguards should be provided to prevent any crew operations that could have catastrophic results.

3.3 Additional Considerations

The entry-control-system design should make effective use of sensors, computers, displays, and other equipment that are onboard the vehicle for other mission phases. It shall be designed to operate within spacecraft and total system constraints, such as weight, power, volume, computer memory, computer execution time, and propellant weight.

The entry-control system should be of a modular design with ready accessibility for ease of inspection, testing, and maintenance.

All interfaces (mechanical, electrical, structural, environmental, computational, crew, etc.) should be compatible with adjoining systems.

4. RECOMMENDED PRACTICES

Procedures and recommended practices for the design of stabilization and control systems for entry vehicles and for the analysis, simulation, and test of such systems are presented.

4.1 Statement of the Problem

It is recommended that at the inception of a spacecraft development program the designer obtain a clear description of the functions to be performed, a definition of the system and vehicle interfaces, a numerical specification of the required control-system performance during entry, and reliability goals for crew safety and mission success. Quantitative control requirements and specifications will be determined by the specific mission objectives and mission constrained entry vehicle characteristics.

It is often not possible to define the entry-control requirements uniquely during the initial design phase. It is important to recognize that the design and development of the spacecraft and its subsystems will be iterative because requirements are time-variant and may change radically, initial design constraints are generally ill defined, inherent characteristics of the spacecraft are not well known, and basic input data for control-system design is frequently not available when needed. Experience has shown that cost, schedule, and other constraints often force major control-system design decisions in spite of the lack of fundamental

information. It is recommended that the designer develop a philosophy of building as much flexibility and adaptability into the entry-control design as practicable to accommodate future contingencies or unexpected problems. In practice, the acceptability of the entry-control system is often judged by performance under extreme off-nominal conditions.

Requirements and constraints should be established for the two distinct flight phases during which the entry-control system must operate:

- (1) The extra-atmospheric portion subsequent to retrofire or final staging, and prior to sensible atmosphere drag deceleration (0.05 g). In this phase, the control system must be capable of holding the required vehicle attitude within specified limits without using excessive propellant.
- (2) The atmospheric portion subsequent to 0.05 g drag and prior to entry into the terminal landing mode. In this phase, the entry-control system must be capable of controlling attitude and attitude rate within specified limits, and damping any vehicle instability.

The entry-attitude and attitude-rate accuracy requirements are of fundamental importance to the design of the entry-control system. However, the complexity of the control itself in terms of logic, signal processing, etc., will increase rapidly as the required control accuracy increases; therefore, caution should be exercised to avoid overspecification. The angular-acceleration requirements to perform maneuvers often determine the maximum level of control torque to be provided by the reaction-jet system. For example, during supercircular entry, critical roll maneuvers must be conducted in a very short time during the maximum g-loading period to establish the proper skipout conditions. This rapid-control-response requirement during initial entry sized the roll reaction-jet thrust magnitude for the Apollo CM.

Other data that the entry-control designer must obtain early in the design include preliminary estimates of vehicle geometry; inertial and hypersonic aerodynamic characteristics; vehicle heating and loading limitations; time histories of typical entry-trajectory characteristics; constraints on weight, power, and volume; and other requirements such as those concerning vibration, mechanical, thermal, humidity, and radiation environments. It is recommended that the sensors, computers, thrusters, and other equipment onboard the vehicle for other mission phases be used for the entry-control system whenever possible. Thus, it is desirable that the entry-control designer have detailed information on the total mission G&C system as soon as it becomes available and insure that any requirements unique to the control system are included in component specifications. In particular, such information as reaction-jet propulsion-system data including jet interference estimates (refs. 73 and 74), propellant-weight limitations, computer memory, and execution-time constraints should be provided. Initially, the above information will, of necessity, be preliminary. As the mission plan and spacecraft design progresses, this information should be updated.

4.2 Performance

Analytical studies, simulation studies, and tests should be conducted to insure that the entry-control-system performance is adequate to fulfill mission requirements. The following practices are recommended for the conduct of these studies.

4.2.1 Performance Analysis

Initial studies should be conducted to determine required performance ranges of the entry-control system and all components, insofar as this is practicable. A dynamic mathematical model of the spacecraft should be developed (ref. 44) that includes the rigid-body dynamics with the kinematic representations, sensor representations, and the complete mathematical model of the control elements.

The initial spacecraft model may include only the primary dynamic effects, neglecting such effects as variable vehicle mass, structural flexibility, and fuel sloshing. The analysis should involve a three-degree-of-freedom rotational model in which only the orientations and angular velocities of the vehicles are involved. Euler equations or Quaternions, for large flightpath angles, in nonprincipal axes for the vehicle rotational accelerations about the yaw, pitch, and roll axes such as those used in references 56 and 75 are recommended.

Candidate entry-control systems should be formulated that use to maximum advantage sensors, computers, displays, and thrusters already planned for installation in the vehicle for other mission phases. These configurations should be investigated initially by linear-analysis techniques (refs. 76 to 80), using the rigid-body dynamic model, assuming all axes uncoupled. Minimum bandwidth consistent with performance requirements should be selected. Gain and phase margins should be established to satisfy performance and stability requirements. Frozen-point analyses at representative points along the entry trajectory should be made, including such critical conditions as the maximum-dynamic-pressure point and the maximum-heating-rate point. During these initial studies, it should be determined which of the candidate configurations is most suitable and whether slight relaxation of performance requirements permits significant simplification of the control system.

The stability analysis conducted at this point should employ root-locus, Bode, or Nyquist diagram techniques (refs. 81 to 83). The analysis may be generalized to handle quasi-linear system configurations if required (ref. 84). This analysis should investigate transient response, steady-state control errors, the sensitivity of the candidate systems to parameter changes, and the extent to which linear control-system techniques are applicable. Other methods of analysis of nonlinear systems, including the methods of Lyapunov (ref. 85), may be used in certain cases.

Where "hard" nonlinearities (deadbands, etc.) are included in the controller, there is no region of linear system operation. In that event, quasi-linearization (describing function) or phase-plane analysis is performed to study the nonlinear elements (ref. 86). If the controller contains sampled-data elements, it is often necessary to use z-transform techniques to study the system (ref. 81). In some cases, when the sampling frequency is high compared to other modes of the system, the sampled-data subsystem may be analyzed as an equivalent continuous system. Caution must be used, however, because the continuous analysis will not display instability and poor transient response, which may be produced by the effects of a finite sampling rate. A z-transform analysis is usually necessary if the sample frequency is less than 10 times larger than the highest significant frequency component of the input to the sampled-data system, or if the sampled-data output frequency can excite elements of the control loop.

4.2.2 Simulation Studies

Simulation studies of the selected entry-control system configuration should be conducted throughout the design, test, and operational program to insure that the system is safe and flightworthy. The studies may begin using computer simulations and rudimentary displays and controls. Increasing realism should be incorporated in these studies as the design progresses. Through these studies, the effects of faulty operation of system elements, crew errors, and off-nominal conditions should be considered to insure that all factors that might impair safety of flight are fully understood and are appropriately eliminated.

It is recommended that a digital or hybrid six-degree-of-freedom simulation be used to conduct these studies. Methods such as those used in reference 87 are recommended for this simulation. The simulation should include man-in-the-loop investigations of the entry-control system coupled with the entry-guidance system. Depending on the vehicle configuration, effects such as structural flexibility and propellant slosh should be investigated. As various system components become defined and available, the actual hardware elements should be tied into the simulation. This practice will allow an understanding and verification of the hardware and software interfaces between the entry-control elements and other subsystems.

Parametric studies to generate technical data to be used for tradeoff decisions should be conducted. It is recommended that the parametric investigation include a determination of the effects of the following:

- (1) Aerodynamic-coefficient uncertainties
- (2) Moment-of-inertia uncertainties
- (3) Principal axes misalignments
- (4) Attitude- and rate-control gain
- (5) Center-of-mass location
- (6) Entry angle of attack

- (7) Landing target location
- (8) Magnitude of attitude-rate commands
- (9) Attitude and rate deadbands
- (10) Roll-yaw coupling gain
- (11) Reaction-jet thrust plus interference level
- (12) Gusts and wind shears
- (13) Single-thruster failure
- (14) Single- versus dual-thruster system operation
- (15) Rate-to-attitude signal mixing ratio
- (16) Pulse-modulation methods for thrusting commands
- (17) Transonic region jet/airflow interaction

The results of the parametric investigation should be analyzed to determine the effects of the preceding on the following:

- (1) Propellant consumption during entry
- (2) Maximum on-time for any thruster
- (3) Number of thruster firings
- (4) Touchdown accuracy of controlled entry
- (5) Angle-of-attack oscillations during maximum heating, maximum dynamic pressure, and transonic flight
- (6) Tolerances on c.m. location
- (7) Control-system sensitivity to landing location
- (8) Limits on gain variations

With this information, decisions relative to system tradeoffs may be made.

4.2.3 Tests

The test plan should be formulated to include performance tests to insure that system and component performance is adequate to meet all anticipated requirements, and to include acceptance tests to insure that flight hardware conforms to design performance requirements.

The test plan should include such laboratory and flight tests as are required to insure that assumptions regarding safety and effects of failure are realistic. The test plan should also include qualification tests to demonstrate the adequacy of flightworthiness of the design.

Any interface problems must be worked out at this time to insure that the integrated system operates as planned in all modes. Tests for electromagnetic interference effects should be performed to verify that no such problems exist. Closed-loop operation of the system

should be checked for all anticipated mission conditions. Final software tests should be conducted to verify the compatibility of the generated commands with the flight programs and mission requirements. Complete man-in-the-loop simulations energizing all the actual hardware components of the control system should be carried out as a final check of the selected system configurations.

After all analyses, simulation, and ground tests have been completed, a flight test program should be considered. For the manned system, a flight test program to insure satisfaction of the crew safety criteria should be combined with other tests to qualify structure, heatshield, etc., if practicable.

4.3 Crew Safety and Mission Success

Early in the design, overall crew safety and mission success goals are established. Crew safety goals expressed in probability terms are typically on the order of 0.995 to 0.999. Mission success goals may fall in the range of 0.90 to 0.95. The entry-control system contribution to the overall crew safety and mission success probabilities must be determined. It is recommended that the techniques of references 88 and 89 be used to determine the entry-control-system contribution to crew safety and mission success. In carrying out this analysis, the basic elements of the control system, including primary, monitor, and backup subsystems, should be arranged into reliability logic diagrams according to their function. From these diagrams, equations defining the probability of successful operation are derived. Component-reliability test data are used to establish the required probabilities that contribute to the control-system total. This analysis should be repeated throughout the design process to verify entry-control-system compliance with the crew safety and mission success criteria.

A failure analysis should be conducted to determine the effects of failure of each wire, joint, terminal, etc., to insure that no single failure can impair mission completion and that no combination of two single failures impairs flight safety. This analysis will serve to identify potential failures and to provide a basis for determining redundancy requirements. In considering the degree of redundancy to be used, only that amount of redundancy necessary for meeting the reliability goals should be used. Thus, excesses in weight, size, power, complexity, and cost will be minimized. Nonredundant designs, when compared to redundant designs, usually result in equipment that is smaller in size and lighter in weight, requires less power, and is less complex. However, the high reliability goals of manned control systems and the numerous connections and dissimilar elements included in control systems in general dictate that some degree of redundancy be used in the design. Redundancy and backup provisions should be provided wherever necessary to achieve mission reliability goals.

Provision should be made for monitoring the operational status of all critical system elements. Wherever manual switchover is relied upon, information provided to the crew should be clear, easily comprehended, legible, and entirely appropriate for the intended purpose. Transition between primary and secondary systems should be accomplished without undesirable transients. Interlocks should be provided wherever inadvertent switching could compromise flightworthiness.

Crew safety considerations dictate that two independent reaction-jet systems with separate propellant supplies, each system adequate to insure safety of flight throughout critical phases of entry, should be provided. Flight-proven hardware should be used wherever such equipment is compatible with reliability and safety-of-flight goals and other design constraints.

PRECEDING PAGE BLANK NOT FILMED

REFERENCES

1. Faget, M. A.; and Piland, R. O.: Mercury Capsule and Its Flight Systems. *Aero/Space Eng.*, vol. 19, no. 4, Apr. 1960.
2. Bond, Aleck C.: Mercury Spacecraft Systems. Proceedings of a Conference on Results of the First U.S. Manned Suborbital Space Flight (Washington, D.C.), June 1961.
3. Kleinknecht, K. S.; Bland, W. M.; and Fields, E. M.: Mercury Spacecraft and Spacecraft Systems. Proceedings of a Conference on Results of the First U.S. Manned Orbital Space Flight (Houston, Tex.), Feb. 1962.
4. Anon.: Project Mercury Familiarization Manual. Rept. SEDR 104, McDonnell Douglas Corp., Dec. 1962.
5. Boynton, J. H.; Fields, E. M.; and Hughes, D. F.: Mercury Spacecraft Systems Development and Performance. Mercury Project Summary. NASA SP-45, May 1963.
6. Chambers, T. V.: Stabilization and Control Systems. Ch. 21 of *Manned Spacecraft: Engineering Design and Operation*, P. E. Pursler, M. A. Faget, and N. F. Smith, eds., Fairchild Pub. Inc., 1964.
7. Johnson, B.: Gemini Spacecraft Guidance and Control Specification. Rept. 8637, McDonnell Douglas Corp., July 1963.
8. Wamser, R. C.: Gemini Guidance and Control Performance Summary. Rept. A344, McDonnell Douglas Corp., June 1965.
9. Carley, R. C.; and Cheatham, D. C.: Gemini Guidance and Control. Paper presented at 16th International Astronautical Congress (Athens, Greece), Sept. 1965.
10. Anon.: Project Gemini Familiarization Manual. Rept. SEDR 300, McDonnell Douglas Corp., Sept. 1965.
11. Carley, R. C.; Schurize, N.; Drone, B. R.; Camp, D. W.; and Hanaway, J. F.: Guidance, Control and Propulsion Systems. Ch. 4 of Gemini Midprogram Conference, NASA SP-121, Feb. 1966.
12. Paddock, S. G., Jr.: The Gemini Reentry Guidance and Control System. Paper presented at 1966 Joint Automatic Control Conference (Seattle, Wash.), Aug. 1966.
13. Malik, P. W.; and Souris, G. A.: Gemini Final Summary Report. Rept. F169, McDonnell Douglas Corp., Feb. 1967.
14. Anon.: Gemini Summary Conference. NASA SP-138, Feb. 1967.

15. Wolfers, C. V.; and Motchan, H. L.: Mercury/Gemini Program Design Survey. Rept. F917, McDonnell Douglas Corp., Jan. 1968.
16. Wright, B. R.; and Kilgore, A. R.: Aerodynamic Damping and Oscillatory Stability in Pitch and Yaw of Gemini Configurations at Mach Numbers from 0.50 to 4.63. NASA TN D-3334, Mar. 1966.
17. Griffith, B. J.: Comparison of Aerodynamic Data From the Gemini Flight and AEDC-VKF Wind Tunnels. *J. Spacecraft Rockets*, vol. 4, no. 7, July 1967, pp. 919-924.
18. Wingrove, R. C.; and Stinnett, G. W.: A Study of the Pilot's Ability to Control an Apollo Type Vehicle During Atmosphere Entry. NASA TN D-2467, Aug. 1964.
19. Chilton, R. G.: Apollo Spacecraft Control Systems. Paper presented at IFAC Symposium on Automatic Control in Peaceful Uses of Space (Stavenger, Norway), June 1965.
20. Duncan, R. C.: Apollo Navigation, Guidance and Control. Apollo Lunar Landing Mission Symposium. NASA TM X-58006, June 1966.
21. Vander Velde, W. E.: Space Vehicle Flight Control. *Space Navigation Guidance and Control*, J. E. Miller, ed., Agardograph 105, Aug. 1966.
22. Martin, F. H.; and Battin, R. H.: Computer Controlled Steering of the Apollo Spacecraft. AIAA Paper 67-603, presented at AIAA Guidance, Control and Flight Dynamics Conference (Huntsville, Ala.), Aug. 1967.
23. Mosley, W. C. Jr.; Graham, R. E.; and Hughes, J. E.: Aerodynamic Stability Characteristics of the Apollo Command Module. NASA TN D-4688, Aug. 1968.
24. Crowder, R. S.; and Moore, J. D.: Apollo Entry Aerodynamics. AIAA Paper 68-1008, presented at AIAA 5th Annual Meeting (Philadelphia, Pa.), Oct. 1968.
25. Cauchon, F. B.; and Peterson, R. L.: Apollo Command and Service Module Stabilization and Control System Design Survey. Rept. SD 68-869, North American Aviation, Inc., Dec. 1968.
26. Anon.: Apollo 7 Mission Report. NASA MSC-PA-R-68-15, Dec. 1968.
27. Anon.: Apollo 8 Mission Report. NASA MSC-PA-R-69-1, Feb. 1969.
28. Anon.: Apollo 9 Mission Report. NASA MSC-PA-R-69-2, May 1969.
29. Anon.: Apollo 10 Mission Report. NASA MSC-00126, Aug. 1969.
30. Saltzman, E. J.; and Garringer, Darwin J.: Summary of Full-Scale Lift and Drag Characteristics of the X-15 Airplane. NASA TN D-3343, Mar. 1966.
31. Yancey, R. B.: Flight Measurements of Stability and Control Derivatives of the X-15 Research Airplane to a Mach Number of 6.02 and an Angle of Attack of 25°. NASA TN D-2532, Nov. 1964.

32. Osborne, R. S.: Stability and Control Characteristics of a 0.0667-Scale Model of the Final Version of the North American X-15 Research Airplane (Configuration 3) at Transonic Speeds. NASA TM X-753, 1963.
33. Walker, H. J.; and Wolowicz, C. H.: Stability and Control Derivative Characteristics of the X-15 Airplane. NASA TM X-714, 1962.
34. Penland, J. A.; and Fetterman, D. E., Jr.: Static Longitudinal, Directional, and Lateral Stability and Control Data at a Mach Number of 6.83 of the Final Configuration of the X-15 Research Airplane. NASA TM X-236, 1960.
35. White, R. M.; Robinson, G. H.; and Matranga, G. J.: Resume of Handling Qualities of the X-15 Airplane. NASA TM X-715, 1962.
36. Tremant, R. A.: Operational Experiences and Characteristics of the X-15 Flight Control System. NASA TN D-1402, Dec. 1962.
37. Taylor, L. W., Jr.; and Merrick, G. B.: X-15 Airplane Stability Augmentation System. NASA TN D-1157, Mar. 1962.
38. Taylor, L. W., Jr.; and Adkins, E. J.: Adaptive Control and the X-15. Paper presented at the Princeton University Conference on Aircraft Flying Qualities, June 1965.
39. Lindahl, J.; McGuire, W.; and Reed, M.: Advanced Flight Vehicle Self-Adaptive Flight Control System, Part VI. Final Flight Test Report. WADD-TR-60-651, Oct. 1963.
40. Lindahl, J.; McGuire, W.; and Reed, M.: Advanced Flight Vehicle Adaptive Flight Control System, Part VII. Final Report on Study, Development, and Test of the MH-96 System for the X-15. WADD TR-60-651, Dec. 1963.
41. Jarvis, C. R.; and Lock, W. P.: Operational Experience with the X-15 Reaction Control and Reaction Augmentation Systems. NASA TN D-2864, June 1965.
42. Taylor, L. W., Jr.; and Smith, J. W.: An Analysis of the Limit-Cycle and Structural-Resonance Characteristics of the X-15 Stability Augmentation System. NASA TN D-4287, Dec. 1967.
43. Taylor, L. W., Jr.: Analysis of a Pilot-Airplane Lateral Instability Experienced with the X-15 Airplane. NASA TN D-1059, Nov. 1961.
44. Holliman, E. C.; and Adkins, Elmor J.: Contributions of the X-15 Program to Lifting Entry Technology. J. Aircraft, vol. 1, no. 6, Nov.-Dec. 1968, pp. 360-366.
45. Holliman, E. C.: Summary of High-Altitude and Entry Flight Control Experience with the X-15 Airplane. NASA TN D-3386, April 1966.
46. Hoey, R. G.: Correlation of X-15 Simulation Experience with Flight Test Results. AGARD Rept. 530, May 1966.

47. Holleman, E. C.: Control Experiences of the X-15 Pertinent to Lifting Entry. NASA TN D-3262, Feb. 1966.
48. Stillwell, W. H.: X-15 Research Results. NASA SP-60, 1965.
49. Fischel, J.; and Webb, L. D.: Flight-Information Sensors, Display, and Space Control of the X-15 Airplane for Atmospheric and Near-Space Flight Missions. NASA TN D-2407, Aug. 1964.
50. Anon.: NASA Board of Review Report on X-15 Flight 3-65 of November 15, 1967. Aviation Week and Space Technology, Aug. 12, 1968, pp. 104-117, and Aug. 26, 1968, pp. 85-105.
51. Bartlett, H. E.; Dean, J. W.; and Owen, A. H.: ASSET-System Description and Evaluation. AFFDL-TR-65-31, Vol. II, Apr. 1966.
52. Anon: Proceedings of ASSET/Advanced Lifting Reentry Technology Symposium. AFFDL-TR-66-22, Dec. 1965.
53. Anon.: Preliminary Design Study of SLAMAST (Scout Launched Advanced Materials and Structures Test Bed). Vol. I, Experimental Feasibility, NASA CR 66397; Vol. II, Design Feasibility, NASA CR 66398; Vol. III, Summary, NASA CR 66399. General Electric Reentry Systems Dept. April 1967.
54. Nelson, R. L.; Price, D. A.; and Delpino, F. H.: A New Concept for Controlled Lifting Entry Flight Experiments. Advanced Programs, Research and Development Division, LMSC, NASA CR 66718, April 1967.
55. Minor, J. W.: Prime Strapdown Guidance System. Transactions of the 11th Symposium on Space and Ballistic Missile Technology, Vol. II, July 1966, pp. 202-242.
56. Wagner, W. E.; and Scrold, A. C.: Statistical Trajectory Estimation Programs. Vol. I, Formulation; Vol. II, Utilization Report. Martin Marietta Corp., NASA CR 66837, December 1969.
57. Osder, S. S.; and Korfila, R. P.: Stabilization and Control of Maneuvering Reentry Vehicles. Sperry Eng. Rev., vol. 18, no. 3, fall 1965.
58. Horowitz, I. M.: Passive-Adaptive Flight Control Design for Reentry Vehicles. Automatica, vol. 2, 1965, pp. 151-165.
59. Schultz W. C.; and Rideout, V. C.: Control System Performance Measures: Past, Present and Future. IRE Transactions on Automatic Control, Feb. 1961.
60. Wingrove, R. C.: A Survey of Atmospheric Reentry Guidance and Control Methods. AIAA J., vol. 1, no. 9, Sept. 1963.
61. Stalony-Dobrzanski, J.: Reentry Guidance and Control Using a Temperature Rate Flight Control System. AIAA Paper No. 65-47, Jan. 1965.

62. Rodden, J. J.: Dynamic Stability and Control of a Small Lifting Reentry Vehicle During Vacuum Flight. Rept. LMSC/577404, Lockheed Missiles Space Co., Aug. 1964.
63. Steketee, F. D.: Dynamic Stability of Space Vehicles. Volume XI, Entry Disturbance and Control. NASA CR-945, Nov. 1967.
64. Anon.: Flight Control Study of a Manned Reentry Vehicle. WADD TR-60-695, Vol. I and II, July 1960.
65. Schorsch, R. H.: Control Systems Theory Applied to Reentry of Aerospace Vehicles. FDL-TDR-64-48, parts I and II, Apr. 1965.
66. Scharnack, D. K.; and Ward, M. D.: Reentry Vehicle Control System Design and Mechanization. AFFDL-TR-66-3, Apr. 1966.
67. Williams, O. S.: Performance and Reliability of Attitude Control Rocket Systems. ARS Paper 952-59, Nov. 1959.
68. Nicklas, J. C.; and Vivian, H. C.: Derived-Rate Increment Stabilization: Its Application to the Attitude-Control Problem. JPL Tech. Rept. 32-69, July 1961.
69. Schaefer, R. A.: A New Pulse Modulator for Accurate D. C. Amplification with Linear or Nonlinear Devices. IRE Transactions on Instrumentation, vol. I-11, no. 2, Sept. 1962.
70. Stephens, R. R.; Rauch, R. P.; and Sturgis, D. L.: Advanced Logistics Spacecraft System. Vol. 5: Subsystems and Weight Analysis, Rept. F738, McDonnell Douglas Corp., Oct. 1967.
71. Kotfila, R. P. and Painter, W. D.: Design, Development, and Flight Test Experience With Lifting Body Stability Augmentation Systems. Paper No. 69-887, AIAA Guidance, Control and Flight Mechanics Conference (Princeton Univ.), Aug. 1969.
72. Sabroff, A. E.: Advanced Spacecraft Stabilization and Control Techniques. AIAA paper no. 67-878, Oct. 1967.
73. Janos, J. J.; and Hoffman, S.: Forces and Moments Produced by Air and Helium Jets Exhausting Parallel to a Flat Plate in a Near Vacuum. NASA TN D-4408, March 1968.
74. Janos, J. J.; and Hoffman, S.: Forces and Moments Due to Air Jets Exhausting Parallel to Large Flat Plates in a Near Vacuum. NASA TN D-5147, April 1969.
75. Meintel, A. J.; Garren, K. R.; and Driscoll, N. R.: Manual Control of High-Altitude Apollo Launch Abort. NASA TN D-3433, June 1966.
76. Truxal, J. G.: Automatic Feedback Control System Synthesis. McGraw-Hill Book Co., Inc., 1955.
77. Savant, C. J.: Basic Feedback Control System Design. McGraw-Hill Book Co., Inc., 1958.

78. Ragazzini, J. R.; and Franklin, G. F.: *Sampled-Data Control Systems*. McGraw-Hill Book Co., Inc., 1958.
79. Newton, G. C.; Gould, L. A.; and Kaiser, J. F.: *Analytical Design of Linear Feedback Controls*. John Wiley & Sons, Inc., 1957.
80. Woestemeyer, F. B.: *General Considerations in the Selection of Attitude Control Systems*. Proceedings of the SAE-NASA Aerospace Vehicle Flight Control Conference (Los Angeles, California), paper 650591, July 1965.
81. Greensite, Arthur L.: *Analysis and Design of Space Vehicle Flight Control Systems*. Vol. III, Linear Systems. NASA CR-822, July 1967.
82. Gardner, M. F.; and Barnes, J. L.: *Transients in Linear Systems*. John Wiley & Sons, Inc., 1942.
83. Bode, H. W.: *Network Analysis and Feedback Amplifier Design*. D. Van Nostrand Co., Inc., 1945.
84. Gibson, J. E.: *Nonlinear Automatic Control*. McGraw-Hill Book Co., Inc., 1963.
85. Lefferts, E. J.: *A Guide of the Application of the Lyapunov Direct Method to Flight Control Systems*. NASA CR-209, April 1965.
86. Greensite, Arthur L.: *Analysis and Design of Space Vehicle Flight Control Systems*. Vol. IV, Nonlinear Systems. NASA CR-823, July 1967.
87. Zvara, J.; Mikami, K.; Thompson, J. H.; and McKeon, K. A.: *Six-Degree-of-Freedom Analysis of Lifting Entry Vehicle Landing*. Vol. II, Digital Computer Program LIFT (Lifting Flight Trajectory) User's Manual. Kaman AviDyne TR-45, June 1967.
88. Tinkelenberg, A. D.; and Ryland, H. R.: *Crew Safety—A Combination of Many Disciplines*. AIAA paper no. 67-934, Oct. 1967.
89. Bland, W. C.; and Fisher, L. R.: *Reliability Through Attention to Detail*. Manned Spacecraft Engineering Design and Operation. Fairchild Pub., Inc., 1964, pp. 409-419.

NASA SPACE VEHICLE DESIGN CRITERIA MONOGRAPHS ISSUED TO DATE

SP-8001 (Structures)	Buffeting During Launch and Exit, May 1964
SP-8002 (Structures)	Flight-Loads Measurements During Launch and Exit, December 1964
SP-8003 (Structures)	Flutter, Buzz, and Divergence, July 1964
SP-8004 (Structures)	Panel Flutter, May 1965
SP-8005 (Environment)	Solar Electromagnetic Radiation, June 1965
SP-8006 (Structures)	Local Steady Aerodynamic Loads During Launch and Exit, May 1965
SP-8007 (Structures)	Buckling of Thin-Walled Circular Cylinders, revised August 1968
SP-8008 (Structures)	Prelaunch Ground Wind Loads, November 1965
SP-8009 (Structures)	Propellant Slosh Loads, August 1968
SP-8010 (Environment)	Models of Mars Atmosphere (1967), May 1968
SP-8011 (Environment)	Models of Venus Atmosphere (1968), December 1968
SP-8012 (Structures)	Natural Vibration Modal Analysis, September 1968
SP-8013 (Environment)	Meteoroid Environment Model-1969 (Near Earth to Lunar Surface), March 1969
SP-8014 (Structures)	Entry Thermal Protection, August 1968
SP-8015 (Guidance and Control)	Guidance and Navigation for Entry Vehicles, November 1968
SP-8016 (Guidance and Control)	Effects of Structural Flexibility on Spacecraft Control Systems, April 1969

SP-8017 (Environment)	Magnetic Fields—Earth and Extraterrestrial, March 1969
SP-8018 (Guidance and Control)	Spacecraft Magnetic Torques, March 1969
SP-8019 (Structures)	Buckling of Thin-Walled Truncated Cones, September 1968
SP-8020 (Environment)	Mars Surface Models (1969), May 1969
SP-8021 (Environment)	Models of Earth's Atmosphere (120 to 1000 km), May 1969
SP-8023 (Environment)	Lunar Surface Models, May 1969
SP-8024 (Guidance and Control)	Spacecraft Gravitational Torques, May 1969
SP-8029 (Structures)	Aerodynamic and Rocket-Exhaust Heating During Launch and Ascent, May 1969
SP-8031 (Structures)	Slosh Suppression, May 1969
SP-8032 (Structures)	Buckling of Thin-Walled Doubly Curved Shells, August 1969

The block 2 configuration, shown in figure 7, improved utilization of the two systems and made them electrically independent, so that a failure in one would not affect the other. In block 2, the G&N computer assumed the primary stabilization and control tasks. A manual and semiautomatic control system served as a backup to the primary system. With the backup attitude reference, the control system was sufficient to allow the crew to make a safe entry in the event of primary G&C system failure. The block 2 design illustrates the philosophy of using two nonidentical systems to achieve functional redundancy.

The entry-control system functional diagram is illustrated in figure 8. Attitude-error and rate-gyro feedback signals were limited to reduce the maximum maneuver rate in the interest of fuel economy. The output of the attitude hand controller was limited for the same reason. The switching amplifier and pseudo-rate logic provided an on-off pulse to the engine-select logic in response to the analog error signal input. The principle of operation of pseudo-rate logic is described in references 6 and 18. During entry ($a > 0.05 g$) and during manual maneuvers, the pseudo-rate feedback was switched out to prevent an overdamped response. The control pulse entered the jet select logic, whose primary function was to provide electrical isolation of the jet driver circuits. The solenoid drivers applied a fixed voltage to the engine-control solenoid valves. Each solenoid control valve had primary and secondary coils. The primary coil provided the normal driving force. The secondary coils

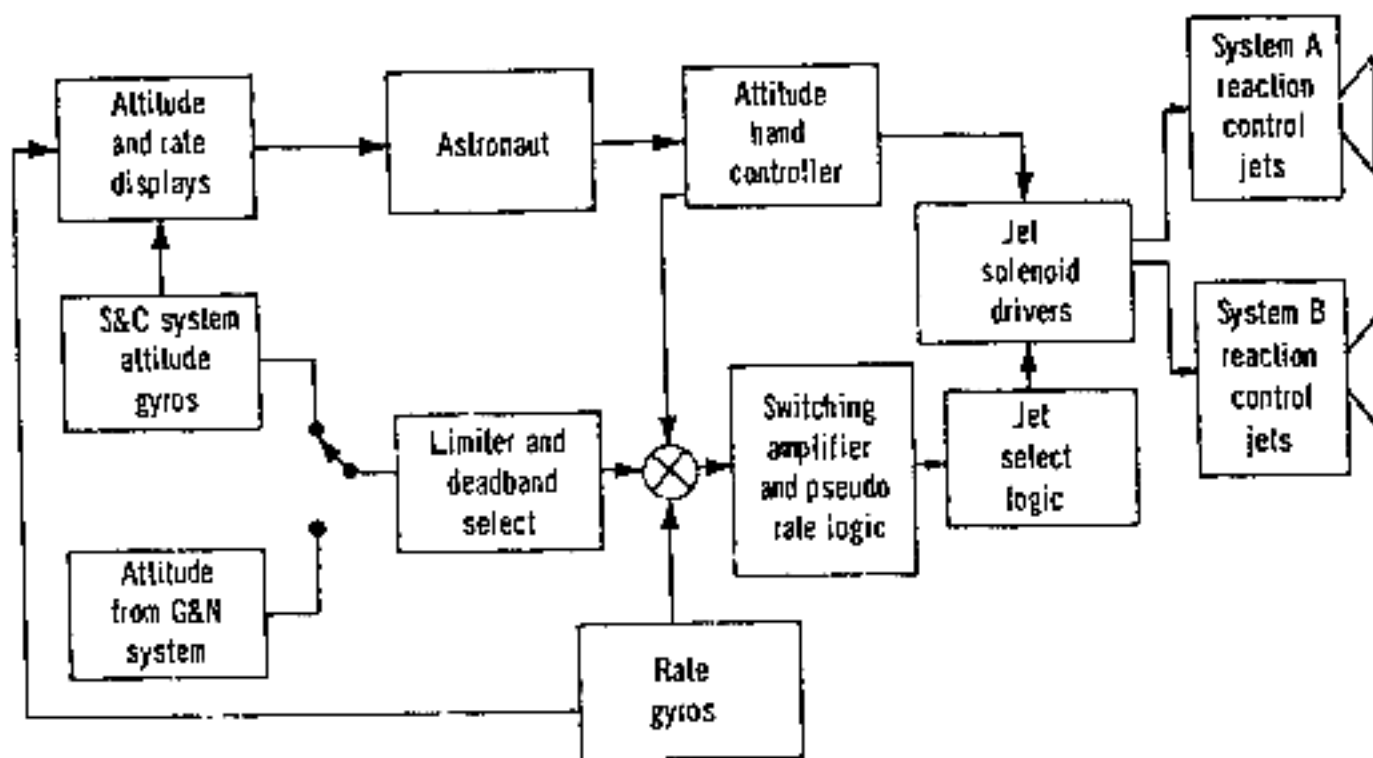

Figure 8.—Apollo entry-control functional diagram.

To: FOIA@msfc.nasa.gov
From: "John Greenewald, Jr." <greeney@primenet.com>
Subject: FOIA Request #98-163
Cc:
Bcc:
Attached:

Dear Ms. Hollingsworth,

This is in response to your letter dated July 07, 1998. Please refer to case #98-163.

If I remember correctly, I only stated that I would agree to pay only up to fifteen dollars for the requested material. I am being charged over \$18.00. As this is not a huge amount, I am a high school student doing valid research and allowing this information to go on an internet web site for everyone to view, at no charge whatsoever. I believe that under the FOIA, I am supposed to be contacted if charges are over my agreed amount.

I also find it unfair since I am a "all other" requester. This entitles me to 2 free search hours, along with 100 free pages. I please ask you process my request as a non-commercial (all other) requester, which I am.

I hope to hear from you as soon as possibly, and please feel free to respond via email. I am going to withhold from sending in the check until I hear from you (unless I do not hear from you by the 31st)

Sincerely,

John Greenewald, Jr.
The Black Vault Site Operator
<http://www.blackvault.com>

From: "Hollingsworth, Judi" <judi.hollingsworth@msfc.nasa.gov>
To: "John Greenewald, Jr." <greeney@primenet.com>
Subject: RE: FOIA Request #98-163
Date: Thu, 16 Jul 1998 09:57:02 -0500
X-Mailer: Internet Mail Service (5.0.2460.8)

As I recall, I notified you via phone that your were requests (you had submitted 2) would be over the \$15.00 you stated in your request and you agreed to the charges. I have talked with our Legal Office concerning your category of requester concern. In our phone conversation, you stated that you were wanting these documents for a website, which you sited on the response back to me. Legal Office has determined that you are a commercial user and the charges you were sited for your request are appropriate. I have your other request which I am processing today. You will be billed \$25.40 for this document (164 pages + \$9.00 search time). If you do not want this document, please notify me by 4:00 CST today (7/16/98) via email or phone at 236-544-1837 and I will not process.

Thank You,
Judi A. Hollingsworth
FOIA Manager

Hollingsworth, Judi, RE: FOIA Request #98-163

To: "Hollingsworth, Judi" <judi.hollingsworth@msfc.nasa.gov>
From: "John Greenewald, Jr." <greeney@primenet.com>
Subject: RE: FOIA Request #98-163
Cc:
Bcc:
Attached:

Dear Ms. Hollingsworth,

Thank you very much for your help on our recent conversation via phone. I hope this does not create any problems or hard work to cancel out the charges.

Just to reiterate, the website that I have created, is fully for research, and does not have any fees to view. It is all free of charge. What I am working on now is a site on the Apollo missions, and have accumulated a few documents regarding Project Apollo.

The main apollo site is located at: <http://www.blackvault.com/nasa/apollo.shtml> if you are interested in checking it out.

The letters of correspondence can be viewed on this page, but for an exact URL to the letter showing me as a non-commercial, please go to:
<http://www.blackvault.com/foia/nasa/guidance/june29.gif>

This was a request for 154 pages, and the Ms. Luna stated the request did not incur charges more than \$5 and the fees were waived. (If she had me as a commercial request, charges would have been \$15.40 plus the search fees)

Also for clarification purposes, in request #98-163, can I have a letter either by email or postal mail stating that the charges have been dropped? Also in the request referenced in your e-mail, regarding charges of \$25.40, what are the fees going to be on this request?

Thank you very much for your time. I appreciate your help in this matter.

Sincerely,

John Greenewald, Jr.

Hollingsworth, Judi, 02:15 PM 7/16/98 , RE: FOIA Request #98-163

From: "Hollingsworth, Judi" <judi.hollingsworth@msfc.nasa.gov>
To: "'John Greenwald, Jr.'" <greeney@primenet.com>
Subject: RE: FOIA Request #98-163
Date: Thu, 16 Jul 1998 14:15:34 -0500
X-Mailer: Internet Mail Service (5.0.1460.8)

The charges for #98-163 have been zeroed out. You do not owe anything for that request. There will be no charges for #98-161. I will be mailing the letter and document today.

Sincerely,
Judi A. Hollingsworth
FOIA Manager