

APPENDIX D

FIGHTING POSITIONS

Fighting positions are stable platforms from which a gunner can engage the enemy. Fighting positions are dug as often as possible, but for the most part only when a unit is in the defense and has the time. This appendix discusses the construction of only two fighting positions: the one-, two-, or three-man, tripod-mounted position; and the M63 antiaircraft emplacement.

D-1. CONSTRUCTION CONSIDERATIONS

When constructing a fighting position, the leader and gunner should consider factors that affect the position, such as cover, concealment, fields of fire, size, and improvements.

a. The cover in a machine gun fighting position protects the gun crew from frontal small-arms fire and from fragments of high explosive shells impacting within 3 to 5 meters of the position. The frontal parapet must be at least one M16 rifle length thick and high enough to hide the helmets of the soldiers in the position. Overhead cover built out of sandbags stacked on logs will protect from shell fragments. The logs should be at least 6 inches thick, with at least two layers of sandbags over them (Figure D-1).

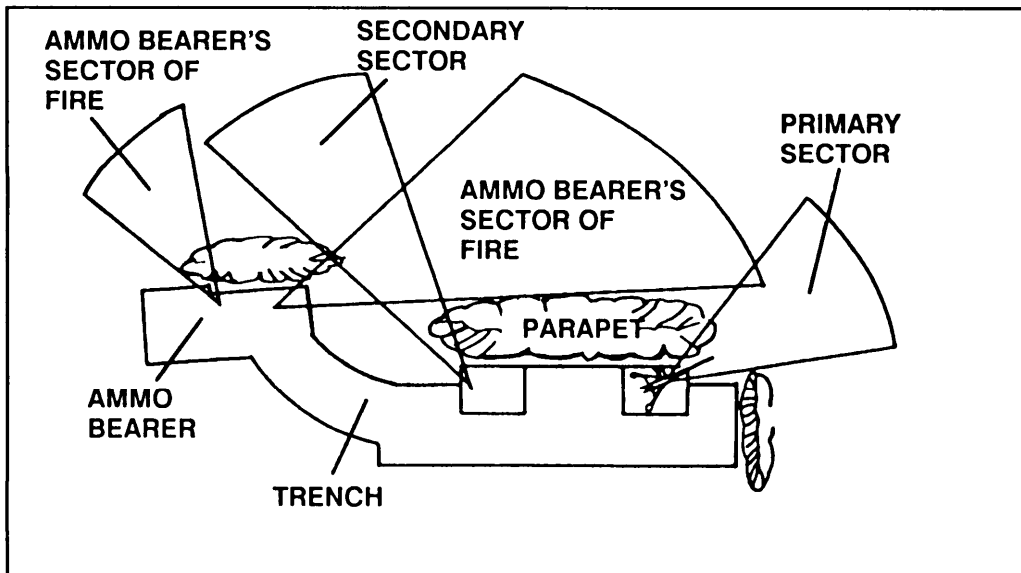

Figure D-1. Three-man fighting position.

b. Concealment hides the machine gun fighting position from direct observation by the enemy, who will make every attempt to locate and destroy heavy machine gun positions early in the battle. The position must be made to blend with its surroundings with both natural and man-made camouflage. Excess dirt from the initial digging should be moved away from the position, and the sod used to re-cover the overhead protection. From the enemy side, the position should not be visible at 35 meters or less (hand grenade range). It should never be obvious even at close range. Use sod or dampen the ground in front of the muzzle to reduce the dust cloud caused by firing. Consider what the position looks like from the air and camouflage it to blend with the surrounding terrain.

c. Selective clearing that does not destroy natural camouflage may be necessary to provide good observation and fields of fire in both primary and secondary sectors of fire.

d. The position should be armpit deep, be wide enough to allow two soldiers with load-bearing equipment to move freely, and have two distinct firing platforms.

e. Improvements to the position may include a grenade sump, a sloping floor with shallow trench for drainage, and a rear parapet for protection against shell fragments and small-arms fire from the rear (other friendly positions or supporting fire from armored personnel carriers).

D-2. CONSTRUCTION OF A TRIPOD-MOUNTED POSITION

After being assigned a sector of fire with an FPL or a PDF, the gun crew begins constructing the fighting position. The tripod is placed in position first and marked so that the weapon will be pointed in the general direction of the target area. A preliminary sketched range card is drawn to show the limits of the sector. The gun crew then outlines the shape of the platform and hole to include the area for the frontal cover in the ground (Figure D-2). The crew then starts digging out the platforms. When they get about 4 to 6 inches deep, the MG is put in place to cover the primary sector of fire until construction is complete.

a. When assigned an FPL, emplace the gun by locking the traversing slide to the extreme left or right of the traversing bar, depending on which side of the primary sector the FPL is on. Align the barrel on the FPL by shifting the tripod.

NOTE: No direction entry is needed in the data section of the range card for the FPL.

b. When assigned a PDF, emplace the gun by locking the traversing slide at the center of the traversing bar. Shift the tripod and gun until the

barrel is aimed at the center of the sector. Check coverage of the sector limits by traversing the gun fully left and right.

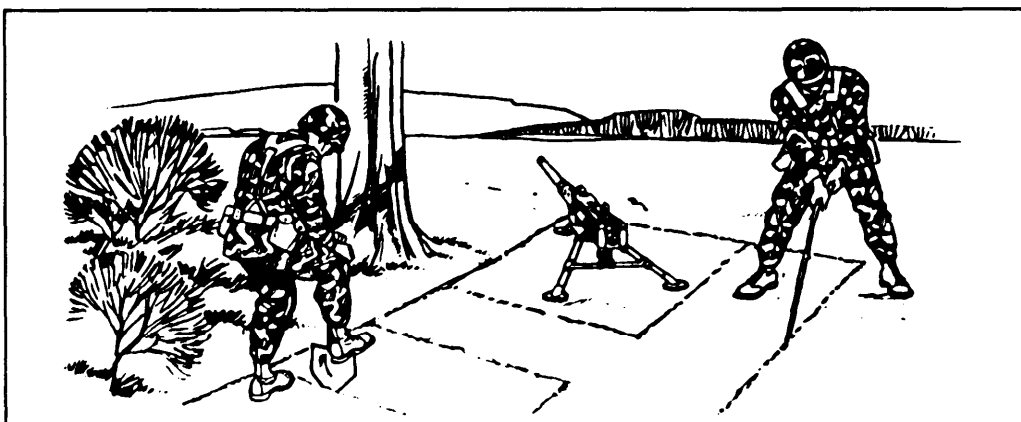

Figure D-2. Planning the fighting position.

NOTE: In the data section of the range card, record the direction and elevation data of the PDF and the sector limits from the T&E mechanism.

c. The crew digging the hole uses the dug-up dirt to build up the cover – first for frontal cover and then for flank and rear cover. They dig the hole deep enough to protect the crew and still let the gunner shoot with comfort (usually about armpit deep) (Figure D-3). They fix the tripod legs in place by digging, sandbagging, or staking them down. This will ensure that the gun does not shift during firing, which would render the range card data useless.

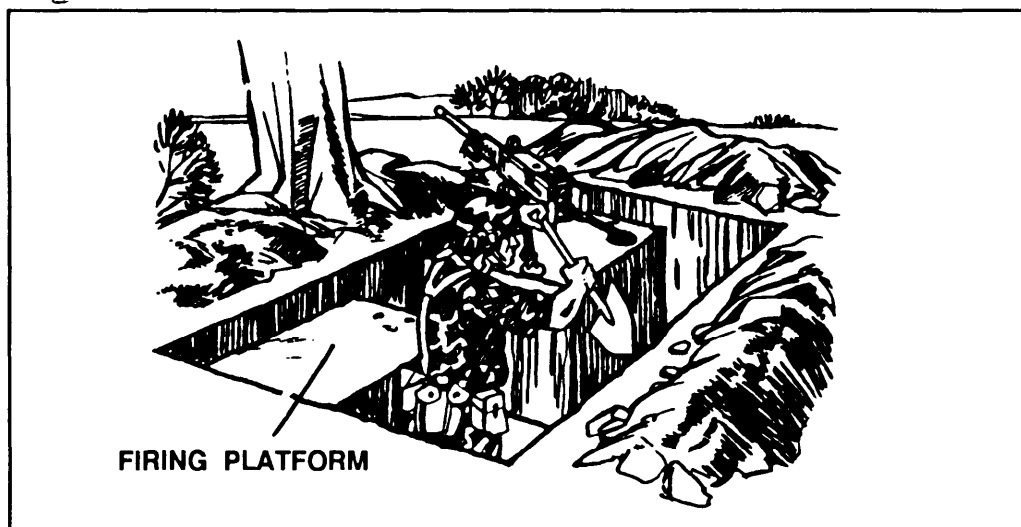

Figure D-3. Digging the fighting position.

(1) The crew digs three trench-shaped grenade sumps at various points where the crew can kick grenades into them (Figure D-4).

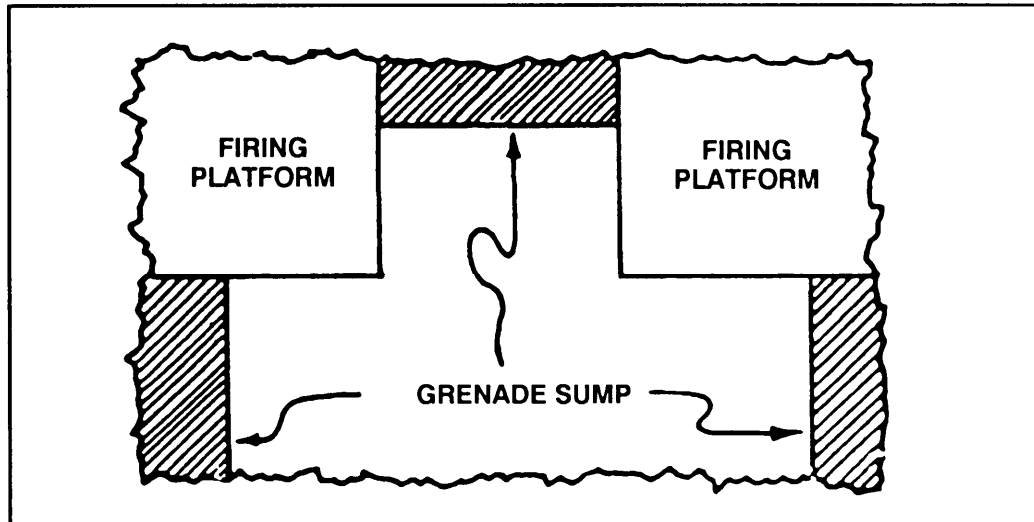

Figure D-4. Digging grenade sumps.

(2) When a position does not have a secondary sector of fire, the crew digs only half of the position (Figure D-5).

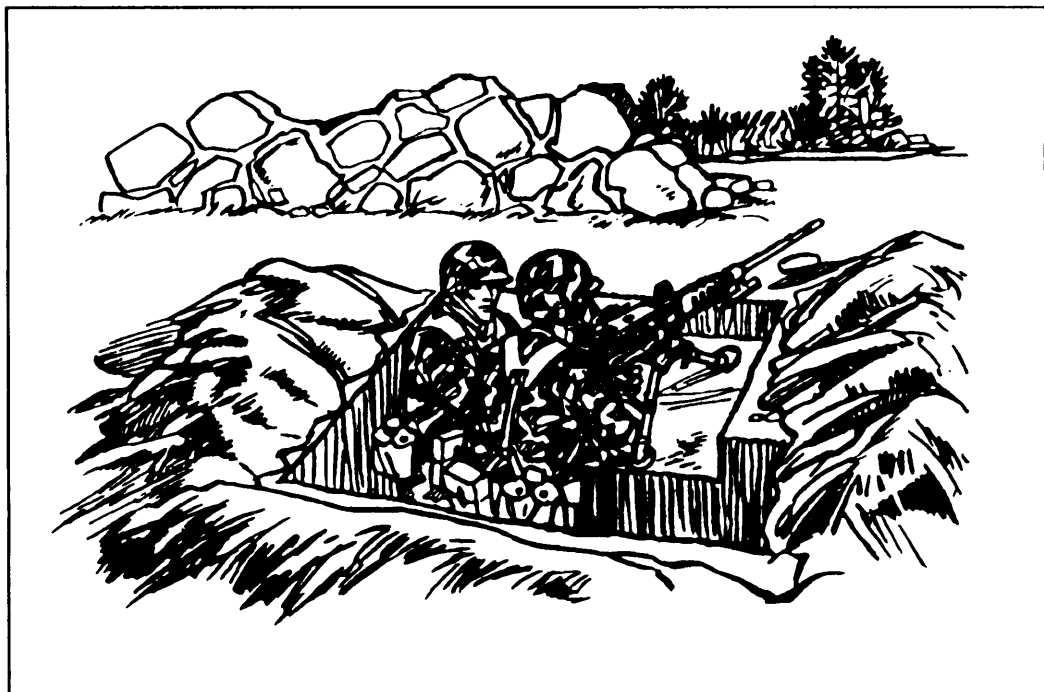

Figure D-5. Half of a position.

(3) When a position has both a primary and secondary sector, the crew prepares two firing platforms. The crew prepares overhead cover for a machine gun position like that of a two-man small arms fighting position. Time and material permitting, overhead cover should extend to cover the firing platforms (Figure D-6). Failure to properly construct overhead cover can result in reduced fields of fire, inability to mount NVDs, or problems in reloading. Proper construction of overhead cover is critical to survival.

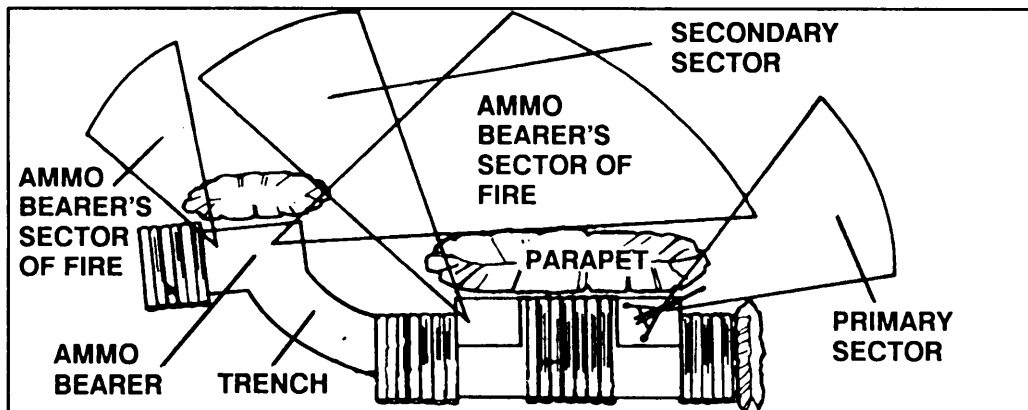

Figure D-6. Two firing platforms with overhead cover.

(4) When there is a three-man crew for the machine gun, the ammunition bearer digs a one-man fighting position to the flank of the gun position so that he can see and shoot to the oblique. This will allow him to cover the front of the machine gun's position (Figure D-7).

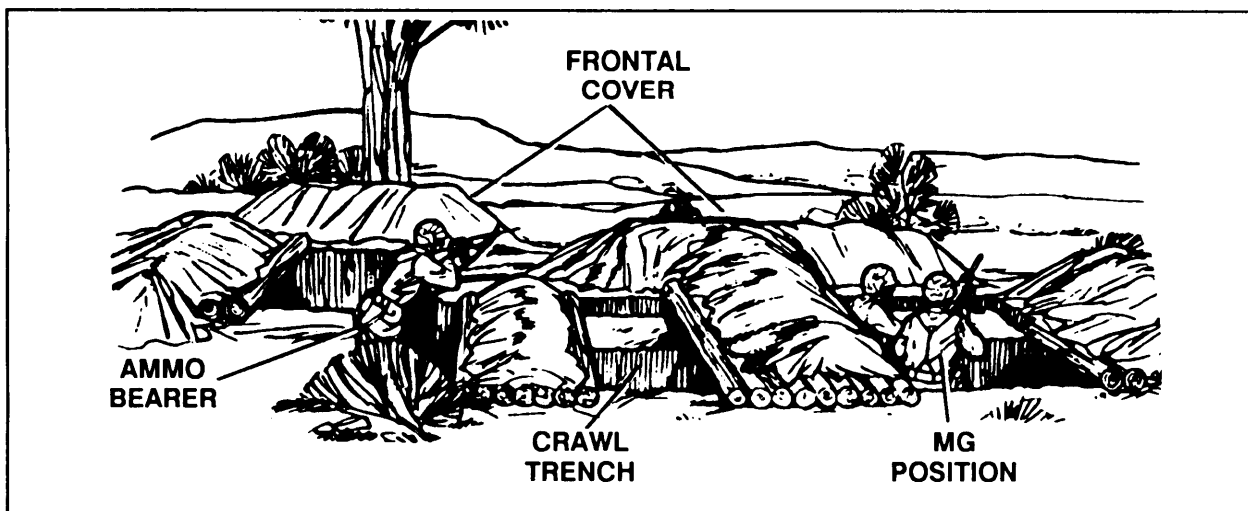

Figure D-7. Ammo bearer covering the front.

D-3. CONSTRUCTION OF AN ANTI-AIRCRAFT EMPLACEMENT

Place the machine gun on the M63 mount alongside the designated location of the gun position. If needed, it can fire at any time during the construction process. Construct a circular position, with sufficient room to traverse the gun 360 degrees (normally, three and a half M16 lengths in diameter and one M16 length deep). Use the dirt dug out of the circular hole to construct a wall of sandbags around the position. Using sandbags, build a stable platform for the mount. Stake down the legs of the mount and place sandbags over them. This will prevent the mount from tipping backward when low-level targets are engaged. Include the M63-mounted machine gun's fire in the plan for defending the unit against ground attack (Figure D-8).

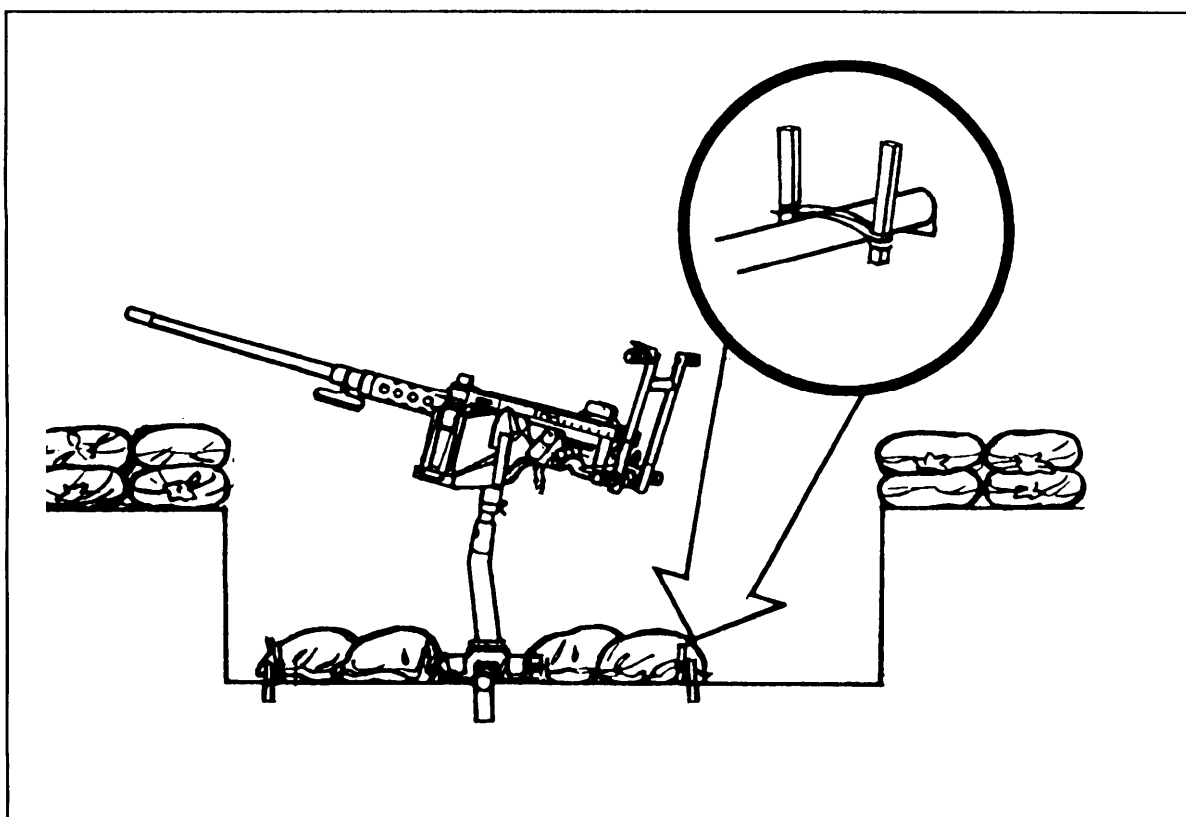

Figure D-8. Open pit-type anti-aircraft position.